

CANADIAN
ELECTRICAL CODE

2009

Saskatchewan Interpretations, Tables, Diagrams & Bulletins



SaskPower

Electrical Inspections Department

Effective: June 1, 2009

For Free Distribution

**This publication is also available on the SaskPower website:
www.saskpower.com**

Version 2.0

PREFACE

As stated in the preface of the Canadian Electrical Code, Sections 0 to 16 and 26 are considered general sections, and the other sections supplement or amend the general sections. Various requirements were revised as a result of the continuing efforts toward harmonization. Section 58 has been added to reflect new technology and industry practices.

The Saskatchewan Interpretations contains no amendatory rules or regulations. SaskPower Electrical Inspection Department is providing the Saskatchewan Interpretations to clarify how the Department is interpreting the 2009 CEC, and to provide diagrams and tables to assist with interpretations of rule changes, as well as Bulletins to provide information to contractors, consultants and electricians on various non-code-specific notices.

CONTENTS

PREFACE	1
----------------------	---

BULLETIN ITEMS:

ITEM 1	VOLTAGE DROP ON SERVICES	5
ITEM 2	AERATION SERVICE CALCULATIONS.....	5
ITEM 3	PROTECTION OF CABLES	5
ITEM 4	PROTECTION OF HEAT TAPES	5
ITEM 5	SUPPORT OF CABLES AND CONDUITS	5
ITEM 6	TEMPORARY WIRING	6
ITEM 7	PERMIT REQUIREMENTS	6
ITEM 8	PRE-INSPECTION OF SERVICES	6
ITEM 9	BUILDINGS HOUSING LIVESTOCK	7
ITEM 10	ELECTRIC HEATERS IN BUILDINGS HOUSING LIVESTOCK	7
ITEM 11	NEUTRAL CONDUCTOR OVERLOAD	7
ITEM 12	USE OF CABLE TIES	7
ITEM 13	CUSTOMER OWNED POLES	7
ITEM 14	OUTDOOR WHEEL CHAIR LIFTS	7
ITEM 15	SEWAGE LIFT AND TREATMENT PLANTS	8
ITEM 16	SASKPOWER SERVICE CONDUCTORS OVER POOLS	8
ITEM 17	APARTMENT BLOCK/ROW HOUSING PERMIT REQUIREMENTS	8
ITEM 18	SASKPOWER ELECTRIC SERVICE REQUIREMENTS.....	8
ITEM 19	RETURN AIR CEILING.....	8
ITEM 20	ELECTRICALLY DRIVEN PIVOT IRRIGATION MACHINES	9
ITEM 21	INTERNET PERMIT ENTRY.....	10
ITEM 22	PERMIT INFORMATION	10
ITEM 23	WEB SITE INFORMATION	10
ITEM 24	BOND NOTICE ADMINISTRATION FEES	11
ITEM 25	LABELS REQUIRED FOR MANUFACTURED HOMES	11
ITEM 26	EQUIPMENT APPROVAL CERTIFICATION.....	11
ITEM 27	REPLACEMENT OF FURNACES.....	11
ITEM 28	ELECTRIC WATER HEATERS.....	11
ITEM 29	PORTABLE GENERATORS.....	11
ITEM 30	RECOGNIZED FIELD INSPECTION CERTIFICATION LABELS.....	12

AMMENDMENTS:

2-035 – Oil and Gas Field Installations	17
---	----

INTERPRETATIONS:

SECTION 2-----General Rules

2-004 – Renewal of Services	18
2-014 – Plans and Specifications.....	18
2-102 (4) – Fires and Floods.....	19
2-306 – Shock and Flash Protection	19

SECTION 4-----Conductors	
4-004 (1)(d) & (2)(d) – Ampacity of Wires and Cables -----	19
(8) – Ampacity of Wires and Cables -----	20
SECTION 6-----Services and Service Equipment	
6-104 – Number of Consumer’s Services Permitted in or on a Building-----	20
6-112 (2)(d) – Support for the Attachment of Overhead Supply or Consumers’	
Service Conductors -----	20
(4) – Support for the Attachment of Overhead Supply or Consumers’	
Service Conductors -----	20
6-200 – Dual Lug Meter Sockets -----	20
6-200 (1) – Service Equipment-----	21
6-206 (1)(c) – Service Equipment -----	21
(1)(e) – Service Equipment-----	21
6-300 – Underground Consumers’ Services-----	21
SECTION 8-----Circuit Loading and Demand Factors	
8-400 – Automobile Heater Receptacles-----	21
SECTION 10-----Grounding and Bonding	
10-700 (2) - Manufactured Grounding Electrodes-----	22
10-812 – Grounding Conductor Size for AC Systems & Service Equipment-----	22
SECTION 12-----Wiring Methods	
12-012 – Burial of Conductors in Proximity to Gas Lines -----	22
12-012 (12) – Underground Raceways or Cables-----	22
12-108 (4) – Conductors in Parallel Above Ground-----	22
12-1118 – Expansion Joints -----	23
12-2200 – Cable Trays-Method of Installation-----	23
SECTION 18-----Hazardous Locations	
18-008 – Grain Handling-----	23
18-010 – Woodworking Plants and Sawmills-----	23
18-068 – Cable Trays in Class II and III Locations -----	24
SECTION 20-----Flammable Liquid and Gas Dispensing and Service Stations, Garages, Bulk Storage Plants, Finishing Processes and Aircraft Hangars	
20-100 – Commercial Garages – Repair and Storage -----	24
20-200 – Residential Storage Garages -----	24
20-400 – Finishing Processes-----	24
– Definitions as per the NFPA 33-----	24
20-400 – Water Base or Waterborne Paint -----	25
20-402 – Paint Mixing Rooms -----	25
20-402 – Limited Finishing Workstations -----	25
SECTION 22-----Locations in Which Corrosive Liquids, Vapours or Excessive Moisture are Likely to be present	
22-002 – Greenhouses-----	25
22-002 – Freezers and Walk-in Coolers -----	26
22-200 – Car Washes -----	26
22-202 – Bulk Fertilizer Storage-----	26
22-204 – Buildings Housing Livestock -----	26
SECTION 24-----Patient Care Areas	
24-000 – Patient Care Areas-----	27
24-104 (2) - Bonding to Ground in Basic Care Areas-----	27
24-110 – Circuits in Intermediate and Critical Care Areas – Diagram 23-----	28

SECTION 26-----Installations of Electrical Equipment	
26-402 – Location of Panelboards -----	28
26-700 (11) – Ground Fault Protected Receptacles -----	28
26-710 – Outdoor Receptacles on Residential Occupancies -----	28
26-712 (d) –Receptacles for Dwelling Units -----	28
26-712 – Tamper Resistant Receptacles for Dwelling Units -----	29
26-722 (f) – Arc Fault Circuit Interrupters -----	29
26-724 – Branch Circuits for Single Dwellings-----	29
SECTION 30-----Installation of Lighting Equipment	
30-100 – Yard Light on Transformer Poles on Farms and Acreages-----	29
SECTION 32-----Fire Alarm Systems and Fire Pumps	
32-000 (1) – Fire Alarm Systems, Fire Pumps and CO Alarms -----	30
32-110 – Smoke and CO Alarms in Dwelling Units -----	30
SECTION 62-----Fixed Electric Space and Surface Heating	
62-114 – Overcurrent Protection and Grouping-----	31
SECTION 68-----Pools, Tubs and Spas	
68-308 – Hydromassage Bathtubs -----	31

TABLES:

D-17	3 PHASE CLASS B MOTORS & CAPACITORS-----	32
D-18	CAPACITOR SWITCHING DEVICES -----	33
D-19	3 PHASE TRANSFORMER FULL LOAD LINE CURRENT-----	34
D-20	1 PHASE TRANSFORMER FULL LOAD LINE CURRENT-----	34
D-21	MINIMUM HIGH VOLTAGE CONDUCTOR CLEARANCES-----	35
D-22	NEUTRAL-SUPPORTED CABLE SAG CHART-----	35
D-23	MAX 3% VOLTAGE DROP -----	36

DIAGRAMS:

Diagram 11	GRAIN ELEVATOR-----	37
Diagram 12	SEED CLEANING PLANT -----	38
Diagram 13	FEED MILL FLOOR PLAN -----	39
Diagram 14	HAZARDOUS LOCATION SEALING-----	40
Diagram 15	REMOVED-----	
Diagram 16	LIMITED FINISHING WORKSTATION W/ exhaust ventilation interlock-----	41
Diagram 17	LIMITED FINISHING WORKSTATION W/O exhaust ventilation interlock-----	41
Diagram 18	TYPICAL SEWAGE LIFT STATION self contained-----	42
Diagram 19	TYPICAL SEWAGE LIFT STATION control building on top -----	42
Diagram 20	TYPICAL SEWAGE LIFT STATION side-by-side -----	43
Diagram 21	TYPICAL SEWAGE TREATMENT PLANT-----	43
Chart	Sewage Lift Station Classification	44
Diagram 22	GFI PROTECTED RECEPTACLES NEAR SINKS -----	45
Diagram 23	PATIENT CARE LOCATION-----	46

ELECTRICAL INSPECTIONS DEPARTMENT:

CONTACTS AND PHONE NUMBERS-----	47, 48
---------------------------------	--------

ELECTRICAL INSPECTIONS DEPARTMENT: DISTRICTS MAP -----	49
---	----

BULLETIN ITEMS

ITEM 1 VOLTAGE DROP ON SERVICES 8-102

Precautions must be taken to prevent any services or branch circuits from exceeding 5% voltage drop from the utility to the end use, with no feeder or branch circuit exceeding 3%. The calculation of voltage drop on services and branch circuits is based on the known load, or 80% of the overcurrent device for unknown loads. See Rule 8-102 and Table D-3 (CEC), and Table D-23 in the back of this publication.

ITEM 2 AERATION SERVICE CALCULATIONS section 28

Services for the supply of motors shall be sized in accordance with Section 28 of the CEC. The service calculation is based on the total number of fans permanently wired into the electrical panel. The motor disconnect shall be installed within sight of and within 9 meters of the motor, or be lockable at the source. If receptacles are installed to plug in the motors, then the service may be calculated by the number of fans to be utilized at one time.

ITEM 3 PROTECTION OF CABLES 4-004, 14-100

Caution must be taken to prevent overloading of cables which do not have customer protection on the supply side. On a farm service center, where the feeder cable terminates in an exterior splitter for the purpose of supplying more than one service, the total amperage of all service breakers may not exceed the ampacity of the feeder cable.

All weather proof splitters must be grounded. This may be achieved by grounding the enclosure to the neutral when on the line side of the service disconnect. When the splitter or junction box is on the branch circuit side, the enclosure shall be bonded with a bond conductor or a metallic raceway.

ITEM 4 PROTECTION OF HEAT TAPES 62-300

All heat tapes require Ground Fault Protection to meet the standards as outlined in Section 62. Ground Fault Protection of heat tapes is equipment protection, and therefore is required to be a Class C type with a minimum 27 MilliAmp trip setting to prevent any nuisance tripping.

The termination of heat tapes requires the use of approved termination kits.

ITEM 5 SUPPORT OF CABLES AND CONDUITS section 12

Permanently installed cables and conduits supplying motors, pumps, pressure switches or any other electrical equipment shall be supported as required by Section 12. Cables and conduits must be supported off of the ground by an approved method such as cable tray, strut, etc. Cables must be supported within 300 mm of any junction box (**this includes oil wells**). When installing cables, you must ensure that there is no stress on the connectors from the weight of the cable.

ITEM 6 TEMPORARY WIRING - Section 76

In buildings under construction or demolition, temporary receptacles of 5-15R and 5-20R configurations are to be ground fault protected. When receptacles that are part of the permanent wiring system of a building under construction are installed, they do not require ground fault protection (e.g. fridge plug). Temporary services must have a main service breaker and be grounded to a grounding electrode (two rods etc.) as per the CEC. When located in a wet location these services must be of weather proof construction. All door hinges shall be located on the sides or bottom, not along the top, of the enclosure to allow for access without supporting the door.

ITEM 7 PERMIT REQUIREMENTS

All low voltage installations including lighting, process controls, solar powered systems, cathodic protection and SCADA systems require permits.

The Electrical Inspections Regulations (available at the Queen's Printer) have been amended to exempt the requirement of an Electrical Permit for the installation of communication cabling as follows:

- 6.1(1) In this section:
- i) "code" means the latest prescribed edition of the Canadian Electrical Code within the meaning of subsection 5(2) of the Act;
 - ii) "communication system" means a communication system as defined in section 0 of the code;
 - iii) "control circuit" means a control circuit as defined in section 0 of the code;
 - iv) "hazardous location" means a location to which Section 18 of the code applies;
 - v) "patient care area" means an area to which Section 24 of the code applies.
- (2) Subsection 16(2) of the Act does not apply to the following types of work of electrical installation:
- (a) the replacement of switches, receptacles, ballasts, lighting fixtures or motors in **single-family dwelling units and in non-detached dwelling units** with separate entrances that are intended for the use of one family
 - (b) the installation of a communication system, other than a communication system:
 - i) that is located in a hazardous location;
 - ii) that is located in a patient care area; or
 - iii) in which control circuits operate the electrical equipment.

ITEM 8 PRE-INSPECTION OF SERVICES

Electrical Services operating at 600A or above **will not** be energized until plans have been received and Electrical Inspections have approved the connection.

High voltage installations, pivot irrigation systems, barns becoming disease free, and sewage treatment facilities are required to be inspected prior to being energized.

It is the responsibility of the Electrical Contractor to arrange for an inspection 2 weeks prior to requesting a service connection.

ITEM 9 BUILDINGS HOUSING LIVESTOCK

In buildings housing livestock, poultry, etc., contractors shall arrange (**two week notice**) for final inspection prior to occupancy. This is to ensure that an inspection is completed before the barn becomes a disease free zone.

**ITEM 10 ELECTRIC HEATERS IN BUILDINGS HOUSING LIVESTOCK
62-104**

Electric heaters for use in buildings housing livestock shall be approved for use where subject to wet or corrosive conditions, or marked Suitable for Use in Buildings Housing Livestock or a similar wording.

ITEM 11 NEUTRAL CONDUCTOR OVERLOAD 4-022

Although the CEC, Part I, does not specifically mention harmonics, harmonics cause heating in the *neutral conductor*. Harmonics caused by certain types of non-linear loads (e.g. office computers, printers, variable speed motor drives, or certain types of electric discharge lighting) should be taken into consideration when sizing *neutral conductors*.

ITEM 12 USE OF CABLE TIES 2-024

The CEC mandates the use of approved straps or other devices to support cables and raceways. However, cable ties used for securing need not be approved. “Securing” should not be confused with “support”. For example, a cable in a horizontal cable tray is supported by the cable tray and may be secured to the tray with cable ties. In the case of a vertical cable tray the cable must be supported by an APPROVED clamp or fastener with the exception of sort drops of 1.5 meters or less.

ITEM 13 CUSTOMER OWNED POLES 12-318

- (1) Additional poles required for support of overhead conductors shall be:
 - (a) 7.5 m or more in length with a minimum top diameter of 125 mm; and
 - (b) Set into the ground at least 1.5 m; and
 - (c) Treated for prevention of rot; and
 - (d) Guyed at corners and dead ends; and
 - (e) Spans of not more than 38 m in length.

ITEM 14 OUTDOOR WHEEL CHAIR LIFTS

In accordance with the manufacturer’s instructions, when a receptacle is required for an outdoor wheel chair lift it shall be a single receptacle connected to a separate circuit and shall not be ground fault protected.

ITEM 15 SEWAGE LIFT AND TREATMENT PLANTS Section 22

These areas are covered under Rules 22-700 to 22-710. These environments may contain multiple hazards, including Class I and Category 1 and 2 locations referenced in Section 18 and 22. Reference can be made to Diagrams 18, 19, 20, & 21

Contractors shall arrange for inspection of new Sewage Lift and Treatment Plants prior to the plant going into service. **Contractors must give a minimum of two weeks notice to the inspector so that a site inspection can be arranged.**

ITEM 16 SASKPOWER SERVICE CONDUCTORS OVER POOLS

SaskPower does not permit any utility service conductors to be located directly over a swimming pool, hot tub or spa. Section 68 of the CEC provides the definition of a swimming pool.

ITEM 17 APARTMENT BLOCK/ROW HOUSING PERMIT REQUIREMENTS

To clarify any confusion that may exist regarding permit requirements for these types of residential units, the following shall apply. Any building containing residential units, regardless whether it is an apartment block, condominium, row housing, etc., will require a permit to cover any electrical work. If the building has a shared exit (i.e., typically an apartment block), only one permit is required to work within multiple residential units within that building, with a detailed description of where and what work was completed. However, if each residential unit has its own exit then a permit is required for each unit. For example, a contractor installs GFCI receptacles in all the bathrooms in a building. If the building has a shared exit only one permit is required for the total cost of the job and the permit fee is calculated as per Table 2. If the residential units within the building each have their own exit, then a permit is required for each unit.

This is consistent with the fee schedule in that Table 1, item 3 deals with the construction of buildings containing residential units and specifies that to group the residential units on one permit there must be a shared exit. As well, Table 1, item 1 deals with permits for residential units with separate exits within a building and a permit is required for each unit.

ITEM 18 SASKPOWER ELECTRIC SERVICE REQUIREMENTS

SaskPower Electric Service Requirements can be found on line at www.saskpower.com or call SaskPower Customer Services at 1-888-757-6937.

ITEM 19 RETURN AIR CEILINGS 12-010

Conductors and cables installed in an area designed to transport or move air as an environmental air system are required to meet the flame spread requirements (FT4).

Transformers and other electrical equipment may be installed in these areas providing there is minimal dust accumulation.

ITEM 20 ELECTRICALLY DRIVEN PIVOT IRRIGATION MACHINES

The following requirements apply to pivot type multi-motor irrigation machines which revolve around a central pivot and employ alignment switches or similar devices to control individual motors.

Contractors shall provide two weeks notice to arrange for a final inspection, prior to the service being energized.

Several Motors on a Circuit

- (1) Several motors, each not exceeding 2 hp rating, may be used on an irrigation machine circuit protected at not more than 30A/600V or less, provided all of the following conditions are met:
 - (a) The full load rating of any motor in the circuit shall not exceed 6A
 - (b) Each motor in the circuit shall have individual running overload protection in accordance with Section 28
 - (c) Taps to individual motors shall be not smaller than 14 AWG copper and not more than 7.5m in length.
- (2) Individual branch-circuit short-circuit protection for motors and motor controllers shall not be required where the requirements of Subrule (1) are met.

The Main Disconnecting Means

The main disconnecting means for a machine shall be located at the point of connection of electrical power to the machine, be readily accessible and capable of being locked in the open position, and have the same horsepower and current ratings as required for the main controller.

Interconnecting Wiring

- (1) Wiring to interconnect the unit collector rings, control panels and motors may be multi-conductor hard usage cables, suitable for outdoor use, as per Table 11, and contain a grounding conductor.
- (2) Cables may be supported along water pipe sections between towers.
- (3) Supporting of cables shall be at intervals not exceeding 1.2 m and within 300 mm of terminal fittings by means of straps, hangers, or similar fittings.
- (4) Where routing of cables is such that additional strain might be imposed on terminal fittings, then supplemental strain relief shall be provided.
- (5) Protection by location, or by supplemental means, shall be provided for cables subject to mechanical damage, such as tower drive motors.

If an irrigation machine has a stationary point, a driven ground rod shall be connected to the machinery at the stationery point for lightning protection with a minimum #6 AWG copper conductor.

Ground fault protection

Ground fault protection is no longer required on irrigation equipment.

However, ground fault protection is required as per Section 26-956 for pumps located within lakes, ponds, dugouts, rivers and streams.

ITEM 21 INTERNET PERMIT ENTRY

Contractors are reminded that they have the option of entering permits online via the Internet permit entry system.

Some of the advantages are:

- Pre-authorized debit withdrawal; no cheques to issue
- Automatic fee calculation
- No need to leave office to deliver permits
- Online permit entry available daily from 7 AM to 11 PM

To receive more information or to see a demo call toll free 1-888-757-6937, option 5.
(Monday to Friday - 8 AM to 12 PM 1PM to 4:30 PM)

ITEM 22 PERMIT INFORMATION

It is the responsibility of the contractor to ensure that the information given on the permit application is accurate and complete. Inaccurate details may result in delayed service connects. In an effort to make the permit process more efficient, please follow these simple rules:

1. If a utility connection or reconnection is required, mark appropriate **YES** box on the permit.
2. If there is no action required by the utility staff, mark the **NO** box.
3. **Ensure the address where the work was performed is accurate and complete.** Additional information is required where no civic address is available (i.e. beaches, new subdivisions and Indian Reserves).
4. Supply work/cell contact phone number in the work description.

Failure to provide accurate and legible information on any permit application could result in the following:

- a) A **\$75.00** assessment fee may be charged to locate missing or inaccurate information, or;
- b) The application and payment may be returned to the contractor to update missing or inaccurate information. A **\$250.00** fine for unreported work may be assessed for any work that is not authorized by a valid permit.

Section 16 of the *Electrical Inspection Act, 1993* and Section 7 of *The Inspection Regulations* specifies that **all permit applications must be accompanied by the appropriate fee.**

ITEM 23 WEB SITE INFORMATION

www.saskpower.com now contains the following information:

- 2009 Interpretations and Bulletins
- District Inspectors contact numbers
- District Inspector territory maps
- Electrical Fee Schedule
- Code for Electrical Installations at Oil and Gas Facilities
- Link to Electrical Act and Regulations
- Electric Service Requirements
- Approved Field Inspection Agencies and Certification Bodies.

ITEM 24 BOND NOTICE ADMINISTRATION FEES

When defects expire a bond notice will be issued and a \$75.00 administration fee, as per Table 4 of the Electric Fee schedule, will be assessed. The invoice will be issued to the contractor at the same time the bond notice is issued to the applicable bond company for completion of said defect.

ITEM 25 LABELS REQUIRED FOR MANUFACTURED HOMES

Manufactured homes (Ready To Move homes) shall have a label affixed to the electrical panel or the inside of the kitchen cabinet. The label shall include the Saskatchewan Electrical Contractor's name, the permit number that was submitted for the installation, and the date. If you require labels, please contact your local electrical inspector to make arrangements.

ITEM 26 EQUIPMENT APPROVAL CERTIFICATION

All electrical equipment requires an overall approval from a Saskatchewan recognized Certification Body prior to being connected electrically. This includes Mobile Homes, Ready to Move Homes, as well as any other manufactured product (new or used). For a complete list of approved Certification Bodies and certification marks please consult the Saskatchewan Interpretations booklet, or visit us on the web at www.saskpower.com.

ITEM 27 REPLACEMENT OF FURNACES

When a furnace is being replaced, the Electrical Contractor is responsible for bonding the gas line as required by the CEC. The branch circuit cable, providing it has an internal bond conductor, and the low voltage thermostat cable do not require replacement.

The furnace shall be provided with a dedicated circuit, and a disconnect where required by the CEC.

ITEM 28 ELECTRIC WATER HEATERS 8-104 (3A)

Water heaters are considered continuous loads and therefore the circuit conductor and overcurrent device shall be loaded to a maximum of 80%.

Example: If the water heater is rated at 3000 watts on 240 volts you will require a #12 AWG conductor and a 20 amp breaker.







ITEM 29 PORTABLE GENERATORS

As with all electrical equipment, portable generators and associated equipment must be approved and carry the mark of a recognized certification agency. Although recommended in the manuals of many power take-off generators, welding cable is not an approved wiring method and will not be accepted. Recessed male receptacles shall be used as an interface to the generator.

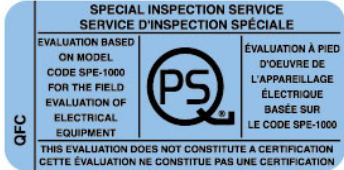
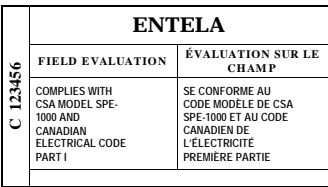
Note: It is not acceptable to permanently install flexible cable out of the transfer panel.

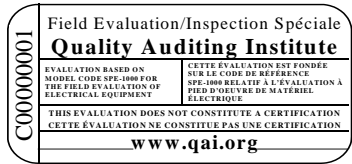
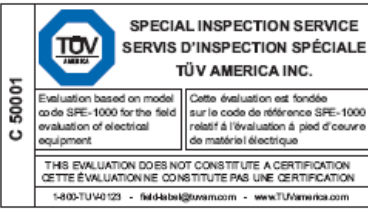
ITEM 30 RECOGNIZED FIELD INSPECTION CERTIFICATION LABELS FOR SASKATCHEWAN

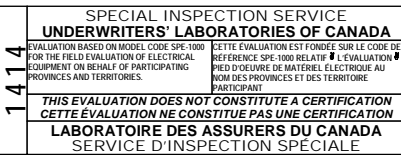
These are field recognized certification labels for the Province of Saskatchewan at the time of printing. To confirm the latest list, contact SaskPower Electrical Inspections at Toll Free at 1-888-757-6937, option 5 or online at saskpower.com

Name of Field Inspection Agency	Special Inspection Label All labels must read: "CSA SPE-1000"	Name of Field Inspection Agency	Special Inspection Label All labels must read: "CSA SPE-1000"
CSA International		QPS	
ETL Intertek Entela		INTERTEK TESTING SERVICES	
ETL Intertek Semko		Quality Auditing Institute	
TÜV America Inc.		TÜV Rheinland of North America, Inc.	
Underwriters Laboratories of Canada		Nemko Canada Inc.	



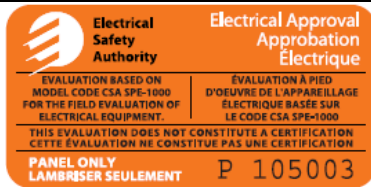









**ELECTRICAL
SAFETY
AUTHORITY
– ESA**











For use on panels only



For use on all electrical equipment covered by the accreditation

Name of Certification Body	Certification Marks	
CSA International		The CSA certification mark alone without any identifier indicates products approved to Canadian National Standards. If another country's identifier is present (i.e., US, NRTL), then the small 'c' Canadian identifier is required to indicate that the product also complies with Canadian National Standards.
		
		
QPS Evaluation Services Inc.		The QPS certification mark requires the small 'c' Canadian identifier to indicate compliance to Canadian National Standards. Identifiers for other countries may be present but in all cases, the small 'c' is required.
Intertek Testing Services NA Ltd. (ETL) (Entela)		The ETL Intertek Entela certification mark requires the small 'c' Canadian identifier at the 8 o'clock position to indicate compliance to Canadian National Standards. Identifiers for other countries may be present but in all cases, the small 'c' is required.
		ETL Intertek Semko has 2 certification marks, the ETL mark and the WH mark. Each mark requires the small 'c' Canadian identifier to indicate compliance to Canadian National Standards. Identifiers for other countries may be present but in all cases, the small 'c' is required.
		
FM Approvals		The FM certification mark requires the small 'c' Canadian identifier to indicate compliance to Canadian National Standards. Identifiers for other countries may be present but in all cases, the small 'c' is required.
Met Laboratories		The MET certification mark requires the small 'c' Canadian identifier to indicate compliance to Canadian National Standards. Identifiers for other countries may be present but in all cases, the small 'c' is required.
Quality Auditing Institute		The QAI certification mark requires the small 'c' Canadian identifier to indicate compliance to Canadian National Standards. Identifiers for other countries may be present but in all cases, the small 'c' is required.
TÜV Product Service		The TÜV Product Service certification mark requires the small 'c' Canadian identifier to indicate compliance to Canadian National Standards. Identifiers for other countries may be present but in all cases, the small 'c' is required.
TÜV Rheinland of North America		The TÜV Rheinland certification mark requires the small 'c' Canadian identifier to indicate compliance to Canadian National Standards. Identifiers for other countries may be present but in all cases, the small 'c' is required.

Name of Certification Body	Certification Marks		
Underwriters' Laboratories			<p>The UL certification mark requires the small 'c' Canadian identifier to indicate compliance to Canadian National Standards. Identifiers for other countries may be present but in all cases, the small 'c' is required.</p>
			<p>The ULC certification mark is a Canada only mark indicating compliance to Canadian National Standards. It does not require a small 'c' Canadian identifier.</p>
Curtis - Struas LLC			<p>The Curtis – Struas LLC certification mark requires the small 'c' Canadian identifier to indicate compliance to Canadian National Standards. Identifiers for other countries may be present but in all cases, the small 'c' is required</p>
NSF International			<p>The NSF International certification mark requires the small 'c' Canadian identifier to indicate compliance to Canadian National Standards. Identifiers for other countries may be present but in all cases, the small 'c' is required</p>
Nemko Canada Inc.			<p>The Nemko Canada Inc. certification mark requires the small 'c' Canadian identifier to indicate compliance to Canadian National Standards. Identifiers for other countries may be present but in all cases, the small 'c' is required</p>
OMNI Environmental Services Inc.**			<p>The OMNI Environmental Services Inc. certification mark requires the small 'c' Canadian identifier to indicate compliance to Canadian National Standards. Identifiers for other countries may be present but in all cases, the small 'c' is required</p>
LabTest Certification Inc.			<p>The Lab Test certification mark requires the small 'c' Canadian identifier to indicate compliance to Canadian National Standards. Identifiers for other countries may be present but in all cases, the small 'c' is required.</p>

CERTIFICATION BODY		SPECIAL/FIELD INSPECTION AGENCIES
<p>CSA (Canadian Standards Association) 1707 94th Street NW Edmonton, Alberta T6N 1E6 Canada</p>	<p>General Queries - 780 450-2111 Standard Sales & Seminars - (780) 490-2007 1-800-463-6727 Fax: (780) 490-2059 E-mail: info@csagroup.org Web Site: http://www.csa.ca</p>	<p>Performs field inspections.</p>
<p>CSA International 178 Rexdale Boulevard TORONTO, ON M9W 1R3 Canada</p>	<p>Mr. Walter Vance, Manager Accreditations and Conformity Assessment (216) 524-4990 Fax: (216) 328-8138 E-mail: walter.vance@csa-international.org Web site: http://www.csa-international.org/</p>	
<p>QPS Evaluation Services Winnipeg, Manitoba Canada</p>	<p>Gerry Dyrda Mobile: (204) 632-4509 Fax: (204) 632-4386 1-888-819-9248 E-mail: info@qps.ca Web Site: http://www.qps.ca</p>	<p>Performs field inspections</p>
<p>Intertek Testing Services NA Ltd. (ETL) 1500 Brigantine Drive Coquitlam, BC V3K 7C1</p>	<p>1-800-668-8378 Web Site: http://www.intertek-etlsemko.com E-mail: inspections@intertek.com</p>	<p>Testing Technologies (ETL) Saskatoon, SK 1-306-664-2415 E-mail: inspections@testing-tech.com Inspections Group Inc. 12010 – 111 Ave. Edmonton, Alberta T5G 0E6 Phone: (780) 454-5048 Fax: (780) 454-5222 Toll-Free: (866) 554-5048 Toll-Free Fax: (866) 454-5222 E-mail: questions@inspectionsgroup.com</p>
<p>FM Approvals 1151 Boston-Providence Turnpike P.O. Box 9102 NORWOOD, MA 02062 USA</p>	<p>Mr. J. Hill Group Manager, Technical Auditing Services Ph: 781 - 255-4972 Fax: 781 - 762-9375 E-mail: john.hill@fmglobal.com Web Site: http://www.fmglobal.com</p>	
<p>MET Laboratories, Inc. 914 West Patapsco Avenue BALTIMORE, MD 21230-3432 USA</p>	<p>Mr. R. Frier, President Ph: (410) 354-3300 ~ Fax: (410) 354-3313 E-Mail: rfrier@metlabs.com Web site: http://www.metlabs.com</p>	

CERTIFICATION BODY		SPECIAL/FIELD INSPECTION AGENCIES
Quality Auditing Institute 2825 Murray Street PORT MOODY, BC V3H 1X3 Canada	Mr. S. Harris, Manager Ph: (604) 461-8378 ~ Fax: (604) 461-8377 E-Mail: sharris@qai.org E-Mail: info@qai.org Web Site: http://www.qai.org	Performs field inspections.
TÜV Product Service, a division of TÜV America Inc. 5 Cherry Hill Drive DANVERS, MA 01923 USA	Mr. G. Minks, Director Certification Body Ph: (978) 739-7000 ~ Fax: (978) 777-8441 E-Mail: gminks@tuvam.com Web Site: www.tuvamerica.com	Performs field inspections.
TÜV Rheinland of North America, Inc. 12 Commerce Road NEWTOWN, CT 06470 USA	Mr. T. R. Calland, P.E., Program Manager Product Safety and Quality International Approvals Ph: (203) 426-0888 ~ Fax: (203) 426-4009 E-Mail: tcalland@us.tuv.com Web Site: http://www.us.tuv.com	
Underwriters' Laboratories of Canada 7 Underwriters Road TORONTO, ON M1R 3B4 Canada	Mr. N. Breton Director, Electrical Operations and Chief Engineer – Canada Ph: (416) 757-3611 Fax: (416) 757-2627 E-Mail: Normand.Breton@ca.ul.com Web Site: http://www.ulc.ca	Performs field inspections
CURTIS-STRAUS LLC 527 Great Road Littleton, MA 01460 U.S.A.	Mr. Jon D. Curtis, P.E. Director of Operations Ph: (978) 486-8880 Fax: (978) 486-3529 E-mail: jcurtis@curtis-strauss.com Web Site: http://www.curtis-strauss.com	
NSF INTERNATIONAL 789 Dixboro Road Ann Arbor, MI 48105	Mr. Craig S. Morr, CEI/CEM Quality Assurance & Organization Safety Manager Ph: (734) 769-5143 Telefax: (734) 827-6849 E-mail: information@nsf-isr.org	
Nemko Canada Inc 303 River Road, Ottawa Ontario, Canada, K1V 1H2	Mr. S.C. Beck Director of Certification Ph: (613) 737-9680 Fax: (613) 737-9691 E-mail: stuart.beck@nemko.com Web Site: http://www.nemko.com	Performs field inspections

CERTIFICATION BODY		SPECIAL/FIELD INSPECTION AGENCIES
OMNI-Test Laboratories, Inc. 5465 SW Western Avenue Suite G Post Office Box 743 Beaverton, OR 97075 USA	Ms. Alana Smith Accreditation Manager Ph: (503) 643-3788 Fax: (503) 643-3799 E-mail: asmith@omni-test.com Web Site: http://www.omni-test.com	
		ELECTRICAL SAFETY AUTHORITY 1 Terrance Matthews Cres., Suite 130 Ottawa Ontario, Canada, K2M 2G3 Mike Moore General Manger Field Evaluation Services Tel: (613) 271-1489 x 4317 or 1-800-559-5356 Fax: (613) 283-7638 Email: http://www.esainspection.net
LabTest Certification Inc. 3133 - 20800 Westminster Highway RICHMOND, BC V6V 2W3	Toll Free: 1-877-247-0494 Local: 604-247-0444 Web Site: www.labtestcert.com Email: info@labtestcert.com	

SASKATCHEWAN AMMENDMENTS

2-035 Oil and Gas Field Installations

Installations for oil and gas fields shall comply with the Safety Codes Council code entitled *Code for Electrical Installations at Oil and Gas Facilities, Third Edition, 2006*, as published and distributed by SaskPower. This document is available through both the SaskPower and Queen's Printer websites.

SASKATCHEWAN INTERPRETATIONS

2-004 Renewal of services

Where a permit is required for a connection or reconnection of an electrical service, or for a reconnection of a service which has been disconnected for more than twelve months, the service shall be made to comply with the requirements of the current Canadian Electrical Code.

Wooden masts will no longer be connected when a permit is required.

2-014 Plans and Specifications

Please submit one copy of plans for review to:

**Gas & Electrical Inspection
Plans Review
1621 Albert Steet
Regina, Sask. S4P 0S1**

**Telephone number:
1-888-757-6937, option 5
Fax Number:
1-306-566-2906**

Major installations where plans have not been submitted may be denied electrical service until such time as plans have been received by the Plans Review Office.

- (1) One copy of plans and specifications as required by section 19 of the Act, shall be submitted for examination and review prior to construction for:
 - (a) Wiring installations of public buildings, industrial establishments, factories, and other buildings in which public safety is involved; or
 - (b) Large light and power installations and the installation of apparatus such as generators, transformers, switch boards or large storage batteries; or
 - (c) Wiring installations where ampacities exceed 200 amps or voltages exceed 300 volts, and in hazardous locations, other than a service station or oil well that has an ampacity equal to or less then 200 amp or a voltage equal to or less then 300 volts; or
 - (d) Such other electrical installations as may be prescribed by the inspection department.
 - (e) Plans for low voltage installations shall contain the following:
 - (i) Calculated loads;
 - (ii) Main and feeder sizes;
 - (iii) Maximum short circuit current available at each point of application of protection devices in installations exceeding 600 amps;
 - (iv) A schematic (one-line diagram) indicating all voltages on the proposed installation;
 - (v) Plan view of the electrical equipment layout.
- (2) Plans for high voltage installations containing the following must be submitted, and a report obtained from the inspection department, before a service connection is authorized:

- (a) Schematic (one line diagram) complete with:
 - (i) All voltages of proposed installation;
 - (ii) Transformer bank capacity
 - (iii) Primary and secondary protective switching devices and short circuit ratings;
- (b) Site Plan
- (c) Electrical arrangement complete with:
 - (i) Plan, elevation and profile views of the electrical and physical arrangement of the equipment
 - (ii) Dimensions to clearly indicate the electrical, physical and work clearances and relative locations of the equipment;
 - (iii) Fencing arrangement;
 - (iv) Grounding details;
 - (v) Provisions for metering equipment;
 - (vi) Copy of the electrical specifications.

(3) Unless requested by the submitter, only those plans with the main service of 600 amp or 300 volts and above will have a written report prepared and returned.

(4) Fees

- (i) Low voltage – No charge, the review will only include the service and sub-service(s).
- (ii) High voltage - \$75.00 per hour, minimum 1 hour charge.

2-102 (4) Fires and Floods

Circuit breakers exposed to floods or fires shall be replaced in accordance with 2-102 (Appendix B). The equipment taken out of service shall be destroyed.

2-306 Shock and Flash Protection

Contractors are required to field mark equipment requiring adjustment, examination, servicing or maintenance while energized with a warning label identifying potential electric shock and arc flash hazard. This applies to all new equipment as well as used equipment that is being returned to service.

See appendix B for labelling requirements.

4-004 (1) (d) & (2) (d) Ampacity of Underground Wires and Cables

To obtain the installation details for the ampacity of underground wires and cables, refer to the 'B' Diagrams in Appendix B and related Tables in Appendix D.

Tables 1, 2, 3, & 4 are not to be used for underground runs, in conductor sizes 1/0 and larger.

4-004 (8) Ampacity of Wires and Cables (Table 5A)

- (1) Conductors in raceways and cables located on roofs directly exposed to the sun shall be deemed to have an ambient temperature of not less than 50 degrees C.
- (2) Conductors in cables placed above the thermal insulation in unventilated attic spaces shall be considered as being exposed to not less than 50 degrees C.
- (3) Subrule (2) pertains to high ambient conditions in unventilated attic spaces. It is to be noted that natural ventilation is not mentioned. A ventilated attic space means a thermostatically controlled mechanical ventilation system that prevents the build up of excessive temperatures in an attic space.

6-104 - Number of Consumer's Services Permitted in or on a Building

The number of consumer's services of the same voltage characteristics, terminating at any one supply service, run to, on, or in any building, shall not exceed four. Buildings requiring more than four will require two supply services. If two supply services on a building are refused by the supply authority, then an electrical room will be required. If the two services are permitted, then they will require a label stating that there are two services, and the location of each.

6-112 (2)(d) Support for the Attachment of Overhead Supply or Consumer's Service Conductors

For the purpose of this rule 'ground normally accessible to pedestrians' includes patios and decks.

6-112 (4) Support for the Attachment of Overhead Supply or Consumer's Service Conductors

Appendix B note to rule 6-112 (4) states an acceptable manner for mast support is one where 3 support clamps are used. Of these, the upper most is required to be a complete through bolt assembly consisting of a minimum 12mm bolt, nut and washer.

6-200 Dual Lug Meter Sockets

200 A and 400 A dual lug meter sockets may be installed where a customer wants two consumer services. The subdivision of the consumer services can be accomplished within the dual lug meter socket provided that the total current rating of the two consumer service disconnects does not exceed the ampere rating of the meter socket.

In rural areas, where a 400A self contained meter socket is used, a service rated disconnect(s) is required immediately after the meter socket. *e.g. 1-400 A or 2-200 A disconnects, etc.*

6-200 (1) Service Equipment

Each consumer's service shall be provided with a single service box, except where a panel board can employ no more than two single-pole breakers, one two-pole breaker, or one three-pole breaker, and its service entrance is rated.

6-206 (1) (c) Service Equipment

Insulated exterior walls are considered an undesirable location for recessing of panels.

6-206 (1)(e) Service Equipment

As close as practicable shall not exceed 6 conduit meters. Where the service box or other consumer's service equipment is located beyond 6 conduit meters from the point where the service conductors enter the building, the conductors shall be run in threaded rigid metal conduit for the entire length.

6-300 Underground Consumers' Services

Underground service entrance cable, as described in Table 19, shall **NO LONGER** be allowed to be supplied from a branch circuit overcurrent device.

This does not apply to farm or oil and gas field distribution systems, where the cables terminate in a splitter or disconnect switch.

8-400 Automobile Heater Receptacles

Receptacles shall be installed with mechanical protection to prevent damage by vehicles by one of the following or other equivalent means:

- (a) Approved manufactured pedestals provided with mechanical protection; or
- (b) Where mechanical protection is not utilized, the receptacles and conduit shall be installed on structures of adequate strength, such as fences or walls, and the receptacles and conduit shall be installed not less than 750mm above finished grade; or
- (c) A reinforced concrete post with a dimension of not less than 300 mm may be used, and shall be installed to a height of not less than 750 mm and a depth of not less than 750 mm. The receptacles and conduit shall be installed on the face of the post not exposed to vehicular damage. The receptacles may, if desired, be installed on the face of the post exposed to vehicles provided the conduit and outlet boxes are installed within the post. Mounting height of the receptacles shall not be less than 750 mm above finished grade. As an alternate to the concrete post a treated wooden post of min. 150 mm x 150 mm may be used.

Conductors for wiring of these receptacles shall have insulation or covering suitable for installation and use at temperatures down to minus 40 degrees C except for conductors approved for and installed underground.

A separate bonding conductor is required in metal conduit as per 10-804.

10-700 (2) Manufactured Grounding Electrodes

All services require one plate, two rods or a field assembled electrode.

We will no longer accept one ground rod for a temporary service, bus shelter, phone booth, cable television distribution equipment, sign or other similar installation; row housing such as semi-detached, duplex, triplex, fourplex; additional service on farms, acreages or single family dwellings where the first service contains at least two rods, one ground plate or a field assembled electrode.

10-812 Grounding Conductor Size for AC Systems and for Service Equipment

The grounding conductor for any AC system is required to meet table 17 when a low impedance return path is available to carry fault currents.

When there is a high impedance ground path then a #6 AWG is required to ground any AC system regardless of the voltage or amperage.

A low impedance ground system would be one which has a continuous metallic water system or other interconnected electrode systems that may provide multiple metallic paths back to the source.

12-012 Burial of Conductors in Proximity to Gas Lines

No electrical wiring shall be installed within 600 mm of a utility natural gas service.

Electrical wiring maybe installed in the same trench as **customer-owned** propane or natural gas lines provided the conductors are placed at a greater depth with a separation of at least 300 mm of earth or 150 mm of earth if a treated plank is installed between the piping and conductor.

Customer owned propane or natural gas lines refers to customer lines supplying customer premises with ounces of pressure. These lines are required to be buried a minimum of 400 mm.

12-012(12) – Underground Raceways or Cables

All underground raceways or cables subject to movement by settlement or frost require provisions to be made to prevent damage to the conductors or the electrical equipment.

The intent of this rule is to avoid damage to the raceway or cable (during settlement/frost) by the addition of a slip sleeve at grade level.

Underground Installations must have a suitable marking tape buried halfway between the cable and grade level, and the tape must extend the entire length of the trench.

12-108(4) – Conductors in Parallel Above Ground see Appendix B.

Where parallel conductors include grounded circuit conductors (neutrals), each parallel set shall have a separate grounded circuit conductor incorporated into the conductor configuration.

12-1118 Expansion Joints (see Appendix B)

PVC conduit shall be installed as per manufacturer's specifications and the CEC. For example, assuming a temperature change of 70 degrees C, this would mean a minimum of one expansion joint be installed for every 12 lineal meters of a conduit run.

12-2200 – Cable Trays – Method of Installation

Cable trays require 600 mm horizontal clearance on one side of cable trays mounted adjacent to one another, or to walls or other obstructions, where the width of the cable tray installation does not exceed 1 m. Where the width of the cable tray installation exceeds 1 m, 600 mm horizontal clearance is required on each side of the tray.

At least one expansion joint shall be installed in any cable tray run where the expansion of the cable tray, due to the maximum probable temperature change during and after installation, can damage the cable tray as per manufactures specifications.

18-008 Grain Handling

All grain handling systems are classified Class II Division 1 locations, with the exception of areas re-classified by a Professional Engineer.

New installations and additions must meet the requirements as illustrated in Diagrams 11, 12 & 13.

18-010 Woodworking Plants and Sawmills

The CEC classifies these areas as Class III Division 1 locations without adequate dust collection. Areas may be re-classified by a Professional Engineer.

For the purposes of this rule, non-commercial residential garages and farm shops will not be considered wood working plants.

The following will be permitted where adequate dust collection equipment is installed.

- (a) Panel Boxes, controllers etc shall be dust tight or in dust tight enclosures.
- (b) Wall surface wiring shall be Threaded rigid, EMT or Teck cable.
- (c) Ceiling surface wiring may be ordinary location wiring methods
- (d) Boxes shall comply with 18-302 (2)
- (d) Concealed wiring may be type AC or NM cable.
- (e) Concealed boxes and fittings may be ordinary type.
- (f) Switch and receptacle covers shall be of the weatherproof type.
- (g) Where duplex receptacles are used, a separate self-closing cover will be required for each section of the receptacle
- (h) General purpose fluorescent lighting fixtures may be installed;
 - (i) If mounted directly on the ceiling; or
 - (ii) If suspended, and provided with adequate dust shields to prevent the accumulation of dust

18-068 CABLE TRAYS IN CLASS II & III LOCATIONS

When Cable trays are installed in Class II & III locations they shall be installed to minimize the build up of dust or fiber on cables.

When installed horizontally tray covers may be required.

20-100 Commercial Garages – Repairs and Storage

Vehicle repair and storage areas with more than three vehicles contain hazardous areas as per 20-102. This includes the indoor parking area of a condo and similar locations.

All adjacent rooms not suitably cut off with a 50mm barrier are classified as hazardous up to 50mm above the parking floor.

Example; an underground parking garage in a condo unit with an electrical room off of the parking area would require a 50mm curb to make the room a standard area.

20-200 Residential Storage Garages

Residential Garages that have an entrance to the basement require a minimum 50mm curb at the top of the landing or the basement will be considered a hazardous location.

Any portion of the garage floor that is below grade will be classified as a hazardous location (i.e. pit.)

20-400 Finishing Processes

This code rule includes all fiberglass processes. Examples of these areas include manufacturing, finishing, and raw material storage areas.

DEFINITIONS AS PER NFPA 33

SPRAY AREA – Any area in which dangerous quantities of flammable or combustible vapours, mists, residues, dusts, or deposits are present due to the operation of spray processes. It can be either enclosed or unenclosed and includes:

- a) any area in the direct path of a spray application process;
- b) the interior of any exhaust plenum and any exhaust duct leading from the spray process;
- c) the interior of any limited finishing workstation, spray booth, or spray room, as herein defined;
- d) the interior of any recirculation particulate filter, solvent concentrator unit, solvent distillation (recovery) unit, or recirculation air supply unit.

UNENCLOSED SPRAY AREA – Any spray area that is not confined by a limited finishing workstation, spray booth, or spray room, as herein defined.

SPRAY BOOTH – A power-ventilated enclosure for a spray application operation or process that confines and limits the escape of the material being sprayed, including vapours, mists, dusts, and residues that are produced by the spraying operation and conducts or directs these materials to an exhaust system.

SPRAY ROOM – A power-ventilated fully enclosed room used exclusively for open spraying of flammable or combustible materials.

VENTILATION – Movement of air that is provided for the prevention of fire and explosion. It is considered adequate if it is sufficient to prevent accumulation of significant quantities of vapour-air mixtures in concentrations over one-fourth of the lower flammable limit.

LIMITED FINISHING WORKSTATION – An apparatus that is capable of confining the vapours, mists, residues, dusts, or deposits that are generated by a spray application process and that meets the requirements of NFPA 33, but does not meet the requirements of a spray booth or spray room, as herein defined.

PREPARATION WORKSTATION – An enclosed, partially enclosed, or unenclosed power-ventilated apparatus that is used to control the dusts and residues generated by surface preparation activities, such as sanding. A preparation workstation is not a limited finishing workstation, spray booth, or spray room, as herein defined.

FLUIDIZED BED – A chamber holding powder coating material, that is aerated from below to form an air-supported, expanded cloud of the powder. The object or material being coated is preheated, then immersed into the cloud.

ELECTROSTATIC FLUIDIZED BED – A chamber holding powder coating material that is aerated from below to form an air-supported, expanded cloud of the powder. The powder is electrically charged with a charge opposite to that of the object or material being coated.

20-400 Water Base or Waterborne Paint

We are starting to see the use of “water base” paints in automotive and other finishing processes. While the base may be water, other components of the paint are flammable and therefore section 20 still applies, unless it can be proven with the MSDS sheets that there are no flammable components involved.

20-402 Paint Mixing Rooms

All paint mixing rooms are classified as Class I Zone 1 locations, unless it can be proven that all the products involved are non-flammable.

20-402 Limited Finishing Workstations

All limited finishing workstations with or without power-ventilation shall be designed as illustrated in Diagrams 16 and 17.

22-002 Greenhouses

All greenhouses are considered a Category 1 location. EMT with rain-tight fittings will be permitted.

The area classification may be reduced to a standard location if ventilation and humidity control are provided.

22-002 Freezers and Walk-in Coolers

All walk-in freezers are a Category 1 location. All walk-in coolers are standard locations.

22-200 Car Washes

Car washes are classified as Category 1 locations. All wiring methods must be approved for wet locations.

22-202 Bulk Fertilizer Storage

All bulk granular fertilizer storage areas are subject to corrosion from a combination of the fertilizer dust and moisture.

Raceways shall be PVC, or aluminum, with fittings and enclosure entries of such design as to not constitute dissimilar metals in contact with each other, and to exclude dust.

Teck 90 cable with non-corrosive fittings shall be permitted to be installed in bulk fertilizer storage structures.

22-204 Buildings Housing Livestock

Wiring in buildings housing live stock shall be the type listed in Table 19 for wet locations. With adequate ventilation wiring approved for a damp location as per Table 19 may be used. Note; Aluminum conductors and Bx (AC 90) cables are not approved for use in buildings housing livestock.

Non-metallic sheathed cables shall be provided with mechanical protection, in the form of rigid steel, rigid non-metallic conduit, or other suitable material, to protect against damage from rodents when:

- (a) installed in exposed locations less than 300 mm above any horizontal surface;
- (b) installed in exposed locations on the side of floor joists or other structural members less than 100 mm below the upper surface of the floor joists or other structural members;
- (c) run in attics; or
- (d) run in concealed spaces.

Appendix B Note to Subrule 22-204(5): Non-metallic sheathed cable is not approved for installation in a continuous raceway system.

Wiring Methods

The wiring methods that are acceptable in buildings housing livestock are;

- 1) PVC Conduit along with PVC boxes, straps and approved expansion joints as required. Wire within the conduit must be approved for a wet location or damp location if the barn is equipped with adequate humidity control.
- 2) Teck 90 Cable along with approved connectors, non corrosive boxes and straps. Note the electrical continuity of the metal armour must be maintained throughout the cable runs.

- 3) NMWU Cable NOTE; NMWU cable cannot be used in any location where it may be susceptible to damage by rodents.
NMWU cannot be run inside the walls, inside the ceiling/attic or any other concealed space in a barn.

When NMWU cable is used, and it has to pass through a location where it may be exposed to rodents, it must be provided with mechanical protection in the form of rigid steel, rigid non-metallic conduit, or other suitable material when;

- a) Installed in exposed locations within 300 mm above any horizontal surface;
- b) Installed in exposed locations on the sides of floor joists or other structural members less than 100mm below the upper surface.

Note: When an office, tack room, or similar room is attached or within the barn, the wiring methods are the same as the rest of the building (i.e. concealed NMWU is not permitted in the walls).

All screws and equipment must be of the corrosion resistant type.

24-000 Patient Care Areas

Patient Care Areas are defined by the CAN/CSA-Z32 standard and include, but not limited to, walk-in medical clinics, dental clinics, chiropractic clinics, optometrists, and others. The CEC's definition of a health care facility was changed to recognize that more and more treatment and testing, previously done in hospitals, is now being done in these facilities,. This means that the specific rooms of a clinic in which treatment is given must be wired in accordance with Section 24 methods.

The health region, clinic, or hospital administrators are the personnel who will determine the area use for their facilities.

24-104(2) Bonding to Ground in Basic Care Areas

The minimum size equipment bonding conductor shall be sized not smaller than the minimum size required for circuit conductors. 24-102(2) states that the minimum size circuit conductor shall be not smaller than No. 12 AWG.

All bond conductors shall be sized in accordance with table 16, with no bonding conductor sized smaller than a No. 12 AWG. e.g.:

- 1 - 40A equipment requires No. 8 AWG (45A) conductor in conduit, this would require a #10 bonding conductor to conform to table 16.
- 2 - 5A equipment or a receptacle circuit would require No.12 AWG circuit conductors [24-102(2)] and a No.12 AWG bond conductor [24-104(2)].

24-104(1) and 4-036 excludes the use of three wire armoured cables, other than ISO-ground cable, as the bond conductor needs to be insulated and shall have a continuous outer finish that is either green or green with one or more yellow stripes.

Non-metallic conduit, NMD cable, and armoured cables with a PVC inner jacket (teck), provide sufficient insulation to permit the use of a bare copper bond conductor, minimum 12 AWG.

24-110 Circuits in Intermediate and Critical Care Areas – Diagram 23

The requirement of 2-wire circuits (e.g. dedicated grounded circuit conductors) applies to the patient care environments within intermediate and critical care areas.

CAN/CSA-Z32 – Patient Care Environment (formally known as patient care location)

A zone in a patient care area that has been preselected for the accommodation of a patient bed, table, or other supporting mechanism, and for the accommodation of equipment involved in patient treatment, and which includes space within the room 1.5 meters beyond the perimeter of the bed in its normal location and to within 2.3 meters of the floor. The patient environment is a zone fixed to the supporting mechanism and does not move with the patient as the patient moves through the health care facility of the room. (See Diagram 23, Figure 1.)

26-402 Location of Panelboards (See Appendix G)

In a retrofit, where an existing service is upgraded at the same location, the new panel need not be lowered. If the location is otherwise un-desirable it shall be made to comply with the current CEC. Reference 6-206 (1)(c).

In all new installations, with the exception of the main breaker or disconnect switch, no branch circuit over current device shall be located at a height greater than 1.7 m above the finished floor.

26-700 (11) Ground Fault Protected Receptacles

In accordance with Diagram 22, all 5-15R and 5-20R receptacles, located within 1.5 meters of any sink, shall be protected by a GFCI.

26-710 Outdoor Receptacles on Residential Occupancies

In accordance with Appendix B, the intent of this rule is that all receptacles installed outdoors of residential occupancies, and within 2.5 meters of finished grade, shall be protected by a GFCI. This includes receptacles installed on buildings or structures associated with the residential occupancy such as garages, carports, sheds, posts and fences.

26-712 (d) Receptacles for Dwelling Units see Diagram 22

At least one receptacle (15A split or 20A T-slot) shall be installed at each permanently fixed island counter space, and or peninsular counter, with a long dimension of 600mm or greater and a short dimension of 300mm or greater, and with a usable counter surface of minimum 300 mm.

26-712 Tamper Resistant Receptacles for Dwelling Units

(g) Except as provided for in Item (h) all receptacles of CSA Configuration 5-15R and 5-20R shall be tamper resistant receptacles and shall be so marked. This does not include the receptacles in a detached garage.

(h) Receptacles dedicated for microwaves, refrigerators, freezers, kitchen counters, or those located in an attic or crawl space, shall not be required to be tamper resistant.

Kitchen counter receptacles mounted on the sides of cabinets (such as 26-710(d) for persons with disabilities) shall be tamper resistant.

26-722 (f) Arc Fault Circuit Interrupters

A dwelling unit with permanently installed cooking facilities (ie; gas or electric range) is deemed to have a cooking facility, and thus requires arc fault protection in the sleeping facilities. Cord connected hot plates, and/or microwaves, do not constitute a cooking facility.

Newly constructed bedrooms require all receptacles to be arc fault protected. Receptacles added to an existing bedroom will require arc fault protection.

26-724 Branch Circuits for Single Dwellings

At least one dedicated separate circuit is required for all outdoor receptacles. More than one dedicated circuit may be installed for outdoor receptacles, but there shall be no interconnection of inside and outdoor receptacles. This does not include the receptacles on a detached garage, or balcony receptacles of apartment buildings.

5-15R or 5-20R receptacles installed in accordance with 26-714(a) for appliances which of necessity are required to be used outdoors, and within 2.5m of finished grade, shall be protected by a GFCI and shall be tamper proof.

Receptacles located in parking lots of apartments, or similar multi-family dwellings, installed solely for the use of automobile heater receptacles in accordance with 8-400, are not required to be GFI.

30-100 Yard Light on Transformer Pole on Farms and Acreages

Subject to Supply Authority approval, the yard light may be mounted on the transformer pole provided:

- (1) it is located below the secondary rack where there is one; and
- (2) with a separation of at least 500 mm between the bottom of the transformer and the fixture base where there is no secondary rack; and
- (3) on the quadrant of the pole which would not interfere with pole climbing and transformer removal.

The pole mount yard light may be fed from the splitter with a minimum #14 awg cable approved for the location. A pigtail socket and 15A fuse (located in the splitter) may be used as over current protection.

32-000 (1) Fire Alarm Systems, Fire Pumps, and Carbon Monoxide Alarms

New construction of residential units shall be pre-wired for interconnected Smoke alarms. CO alarms shall be installed as required by the National Building Code 9.10.19.2 AND 9.32.3.8 and/or CSA Standard CAN/ULC S531.

CO alarms will be required in residences with fuel burning appliances or an attached garage.

32-110 Smoke and Carbon Monoxide Alarms in Dwelling Units (Appendix B)

The National Building Code requires Smoke Alarms to be permanently connected to an electrical circuit. This circuit may be 120 volt or an extra low voltage system. In either case the circuit must be permanently installed and supplied from a lighting branch circuit. This circuit must not be Arc-fault or Ground-fault protected. In the case of an extra low voltage circuit the transformer must be permanently connected.

Carbon Monoxide Alarms may be battery operated or connected to the lighting branch circuit.

62-114 Overcurrent Protection and Grouping (See Appendix B)

The following information has been prepared for ease of reference when sizing over current protection and conductor sizes for heating equipment

Electric Furnaces and Other Heating Equipment
 Single Phase 240v
 Ref. C.E.C. 62-114 (6) and (7)

Nameplate Furnace Rating (KW)	Conductor Size		Fuse or C.B. Rating
	Copper	Aluminum	
5 KW	No. 10 AWG R90	No. 8 AWG R90	30 Ampere
10 KW	No. 6 AWG R90	No. 6 AWG R90	60 Ampere
15 KW	No. 4 AWG R90	No. 2 AWG R90	100 Ampere
18 KW	No. 4 AWG R90	No. 2 AWG R90	100 Ampere
20 KW	No. 3 AWG R90	No. 1 AWG R90	125 Ampere
23 KW	No. 3 AWG R90	No. 1 AWG R90	125 Ampere
25 KW	No. 2 AWG R90	No. 0 AWG R90	150 Ampere
30 KW	No. 1 AWG R90	No. 00 AWG R90	175 Ampere

A sample selection for a 20 KW furnace follows: The ampacity of the conductors supplying the furnace and the size of the over current devices are determined by applying Rule 62-114.

The over current device for the service must be sized so that the total connected load of the heating equipment does not exceed 80% of the rating of the over current device in accordance with sub rule (6). In this case, the load is 83.3 amps; the minimum size of over current device is $83.3 / 0.8 = 104$ Amperes. The next available fuse is 125 Amperes.

Since this fuse is supplying a heating load, Rule 14-610 requires that the fuses be a time delay type or HRC Form I.

The conductor size is determined by applying sub rule (7) of 62-114. The conductor must have the ampacity sufficient to carry the load, must have an ampacity rating at least 80% of the rating or setting of the branch circuit over current device. A conductor rated at 100 amperes, i.e., #3 AWG R90 (Column 3 of Table 2) would satisfy these requirements.

Based on the conduit fill requirements of Rule 12-1014 and Tables 6 and 10, it can be determined that the 2 #3 AWG R90 conductors require a 1" conduit.

68-308 Hydromassage Bathtubs

No unassociated equipment is to be fed from a circuit feeding a hydro massage bathtub.

TABLES

Table D-17

Table D-17 suggested maximum capacitor rating when motor and capacitor are switched as a unit (For 3-phase, 60 Hz NEMA Class B motors to raise full-load power factor to 95%)

MOTOR RATING HP	NOMINAL MOTOR SPEED IN RPM											
	3600		1800		1200		900		720		600	
	CAPS KVARs	AMPERE REDUCE %	CAPS KVARs	AMPERE REDUCE %	CAPS KVARs	AMPERE REDUCE %	CAPS KVARs	AMPERE REDUCE %	CAPS KVARs	AMPERE REDUCE %	CAPS KVARs	AMPERE REDUCE %
3	1.5	14	1.5	15	1.5	20	2	27	2.5	35	3.5	41
5	2	12	2	13	2	17	3	25	4	32	4.5	37
7.5	2.5	11	2.5	12	3	15	4	22	5.5	30	6	34
10	3	10	3	11	3.5	14	5	21	6.5	27	7.5	31
15	4	9	4	10	5	13	6.5	18	8	23	9.5	27
20	5	9	5	10	6.5	12	7.5	16	9	21	12	25
25	6	9	6	10	7.5	11	9	15	11	20	14	23
30	7	8	7	9	9	11	10	14	12	18	16	22
40	9	8	9	9	11	10	13	13	15	16	20	20
50	12	8	11	9	13	10	15	12	19	15	24	19
60	14	8	14	8	15	10	18	11	22	15	27	19
75	17	8	16	8	18	10	21	10	26	14	32.5	18
100	22	8	21	8	25	9	27	10	32.5	13	40	17
125	27	8	26	8	30	9	32.5	10	40	13	47.5	16
150	32.5	8	30	8	35	9	37.5	10	47.5	12	52.5	15
200	40	8	37.5	8	42.5	9	47.5	10	60	12	65	14
250	50	8	45	7	52.5	8	57.5	9	70	11	77.5	13
300	57.5	8	52.5	7	60	8	65	9	80	11	87.5	12
350	65	8	60	7	67.5	8	75	9	87.5	10	95	11
400	70	8	65	6	75	8	85	9	98	10	105	11
450	75	8	67.5	6	80	8	92.5	9	100	9	110	11
500	77.5	8	72.5	6	82.5	8	97.5	9	107.5	9	115	10

Information Only

Table D-18

CAPACITOR SWITCHING DEVICES

CAP RATING		AMPERES		CAP RATING		AMPERES		CAP RATING		AMPERES	
Volts	kVAr	Cap Amps	Fuse, PC or MC Brkr	Volts	kVAr	Cap Amps	Fuse, PC or MC Brkr	Volts	kVAr	Cap Amps	Fuse, PC or MC Brkr
240	2.5	6.01	15	480	2	2.41	15	600	5	4.81	15
	5	12	20		5	6.01	15		10	9.62	15
	7.5	18	30		7.5	9	15		15	14.4	20
	10	24.1	40		10	12	20		20	19.2	30
	15	36.1	50		15	18	30		25	24.1	40
	30	72.2	100		20	24	40		30	28.9	40
					25	30	50		40	38.5	70
	45	108	150		30	36.1	50		50	48.1	70
	60	144	200								
	75	180	250		40	48.1	70		60	57.8	90
	90	217	300		50	60.1	90		75	72.2	100
	120	289	400		60	72.2	100		80	77	125
	135	325	500		75	90.2	125		100	96.2	150
					80	96.2	150		120	115	175
	150	361	500		90	108	150		125	120	175
	180	433	600		100	120	175		150	144	200
	225	541	800		120	144	200				
	240	578	800						160	154	225
	270	650	1000		125	150	200		180	173	250
	360	866	1200		150	180	250		200	192	300
					160	192	300		225	217	300
					180	216	300		240	231	350
					200	241	350		250	241	350
					225	271	400		300	289	400
					240	289	400				
					250	301	400		320	306	500
									360	347	500
					300	361	500		375	361	500
					320	385	600		400	385	600
					360	433	600		450	433	600
					375	451	600				
					400	481	800				
					450	541	800				

Information Only

Table D-19

THREE PHASE TRANSFORMER FULL LOAD LINE CURRENT IN AMPERES

Kva	208v	240v	480v	600v	2400v	4160v	13800v	14400v
3	8.3	7.2	3.6	2.9	0.72	0.42	0.126	0.120
6	16.6	14.4	7.2	5.8	1.46	0.82	0.251	0.241
9	25	21.7	10.8	8.7	2.17	1.25	0.377	0.361
15	41.7	36.1	18.2	14.5	3.61	2.09	0.628	0.601
30	83.4	72.3	36.1	28.9	7.23	4.17	1.26	1.202
45	125	108	54.2	43.4	10.8	6.26	1.88	1.805
50	139	120	60.2	48.2	12	6.96	2.09	2
75	208	181	90.3	72.3	18.1	10.4	3.14	3.005
112.5	313	271	135	108	27.1	15.7	4.71	4.51
150	417	361	181	145	36.1	20.9	6.28	60.1
200	556	482	241	193	48.2	27.8	8.37	8.02
225	625	542	271	217	54.2	31.3	9.41	9.025
300	834	723	361	289	72.3	41.7	12.55	12.02
450	1249	1083	541	433	108	62.5	18.83	18.04
500	1390	1204	602	482	120	69.6	20.92	20.07
750	2082	1804	902	722	180	104	31.38	30.07
1000	2776	2406	1203	962	241	139	41.84	40.09
1500	4164	3608	1804	1443	361	208	62.76	60.14
2000	5552	4811	2406	1925	481	278	83.67	80.19

$KVA = 1.73 \text{ (Voltage) (Current) / } 1000$

Reference Engineering Handbook

Table D-20

SINGLE PHASE TRANSFORMER FULL LOAD LINE CURRENT IN AMPERES

kVA	120v	240v	480v	600v	2400v	4160v	14400v
2	16.7	8.3	4.2	3.3	0.83	0.48	0.14
3	25	12.5	6.3	5.0	1.25	0.73	0.21
5	41.7	20.8	10.4	8.3	2.08	1.2	0.35
7.5	62.5	31.3	15.6	12.5	3.13	1.8	0.52
10	83.3	41.7	20.8	16.7	4.17	2.4	0.69
15	125	62.5	31.3	25.0	6.25	3.6	1.04
20	167	83.3	41.7	33.3	8.33	4.8	1.39
25	208	104	52.1	41.7	10.4	6.0	1.74
30	250	125	62.5	50.0	12.5	7.2	2.08
37.5	313	156	78.0	62.5	15.6	9.0	2.61
50	417	208	104	83.3	20.8	12	3.47
75	625	313	156	125	31.3	18	5.21
100	833	417	208	167	41.7	24	6.94
167	1391	695	347	278	69.6	40.1	11.6
200	1667	833	417	333	83.3	48.1	13.9
250	2083	1041	520	416	104	60.1	17.4
333	2115	1387	693	555	138	80	23.1
500	4167	2083	1042	833	208	120	34.7
750	6250	3125	1563	1250	313	180	52.1
1000	8333	4167	2083	1667	417	240	69.4

$KVA = \text{Voltage (Current) / } 1000$

Reference Engineering Handbook

Table D-21

Minimum Distances from Exposed Energized High Voltage Electrical Conductors

Risk Factor		Column 1	Column 2	Column 3	Column 4	Column 5	Column 6
Voltage Phase to Phase	Voltage to Ground	Non-electrical Workers, Material, Equipment	Qualified Electrical Workers	Vehicles and Load	Limit of approach for utility tree trimmers using conducting objects exposed to energized parts	Limit of approach for utility tree trimmers using rated tools to exposed energized parts	Limit of approach for utility tree trimmers using rated insulating booms
kV	kV	Metres	Metres	Metres	Metres	Metres	Metres
230	133	6.1	1.4	1.83	2.4	1.41	1.85
138	79.8	4.6	1	1.22	1.9	0.92	1.35
72	41.6	4.6	0.6	0.8	1.6	0.61	1.05
25	14.4	3	0.3	0.6	1.2	0.12	0.55
15	8.6	3	0.3	0.6	1.1	0.12	0.55
4.16	2.4	3	0.15	0.6	1.05	0.04	0.50
0.75	0.75	3	0.15	0.6	1.05	0.04	0.05

Reference OH&S Regulations Table 22

Table D-22

**SAG CHART
(12-318 and 6-112) (Appendix B)**

RECOMMENDED SAGS FOR NEUTRAL-SUPPORTED CABLE												
	2-No. 1/0 Al 1-No. 1/0 Bare ACSR Span in Meters				2-No. 2 Al 1-No. 2 Bare ACSR Span in Meters				2-No. 4 Al 1-No. 4 Bare ACSR Span in Meters			
Temp.	15	23	30	38	15	23	30	38	15	23	30	38
Deg. C	Sag in Centimeters				Sag in Centimeters				Sag in Centimeters			
-29	25	58	102	157	20	43	76	119	18	43	76	119
-18	28	58	104	163	20	46	81	127	20	46	79	124
0	28	61	109	170	23	48	86	135	20	46	81	130
16	28	64	114	178	23	53	94	147	20	48	84	132
32	30	66	117	183	25	56	99	155	23	51	89	137

Table D-23

MAX 3% VOLTAGE DROP

Values in Ampere-feet

Copper conductor

Distances shown are in Ampere-feet. Divide the number in the table by the amperes to obtain feet.

For aluminum conductors find the correct size of copper conductor and add two AWG sizes.

3 phase	#14	#12	#10	#8	#6	#4	#3
208V	1047	1664	2646	4211	6681	10648	13391
480V	2416	3840	6107	9717	15418	24573	30901
600V	3020	4800	7634	12146	19272	30717	38627
3 phase	#2	#1	1/0	2/0	3/0	4/0	
208V	16865	21370	26897	33950	42740	53908	
480V	38919	49315	62069	78346	98630	124404	
600V	48649	61644	77586	97933	123288	155505	
1 phase	#14	#12	#10	#8	#6	#4	#3
120V	604	960	1527	2429	3854	6143	7725
240V	1208	1920	3053	4858	7709	12287	15451
347V	1790	2840	4520	7180	11352	18078	22638
1 phase	#2	#1	1/0	2/0	3/0	4/0	
120V	9730	12329	15517	19587	24658	31101	
240V	19459	24658	31034	39173	49315	62202	
347V	28740	36419	45868	57975	73035	91343	

Reference SaskPower Inspections

DIAGRAMS

Diagram 11 GRAIN ELEVATOR

18-008

HAZARDOUS AREA CLASSIFICATION

CLASS II
DIVISION 1

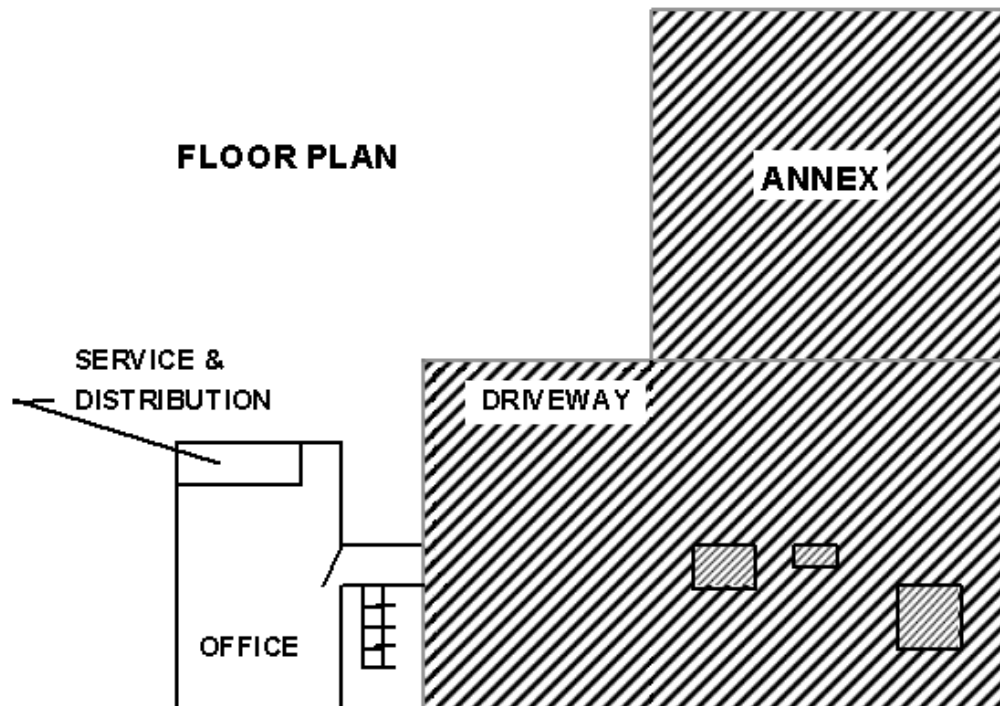

DIAGRAM 12
MAIN FLOOR PLAN
SEED CLEANING PLANT
18-008

HAZARDOUS AREA CLASSIFICATION

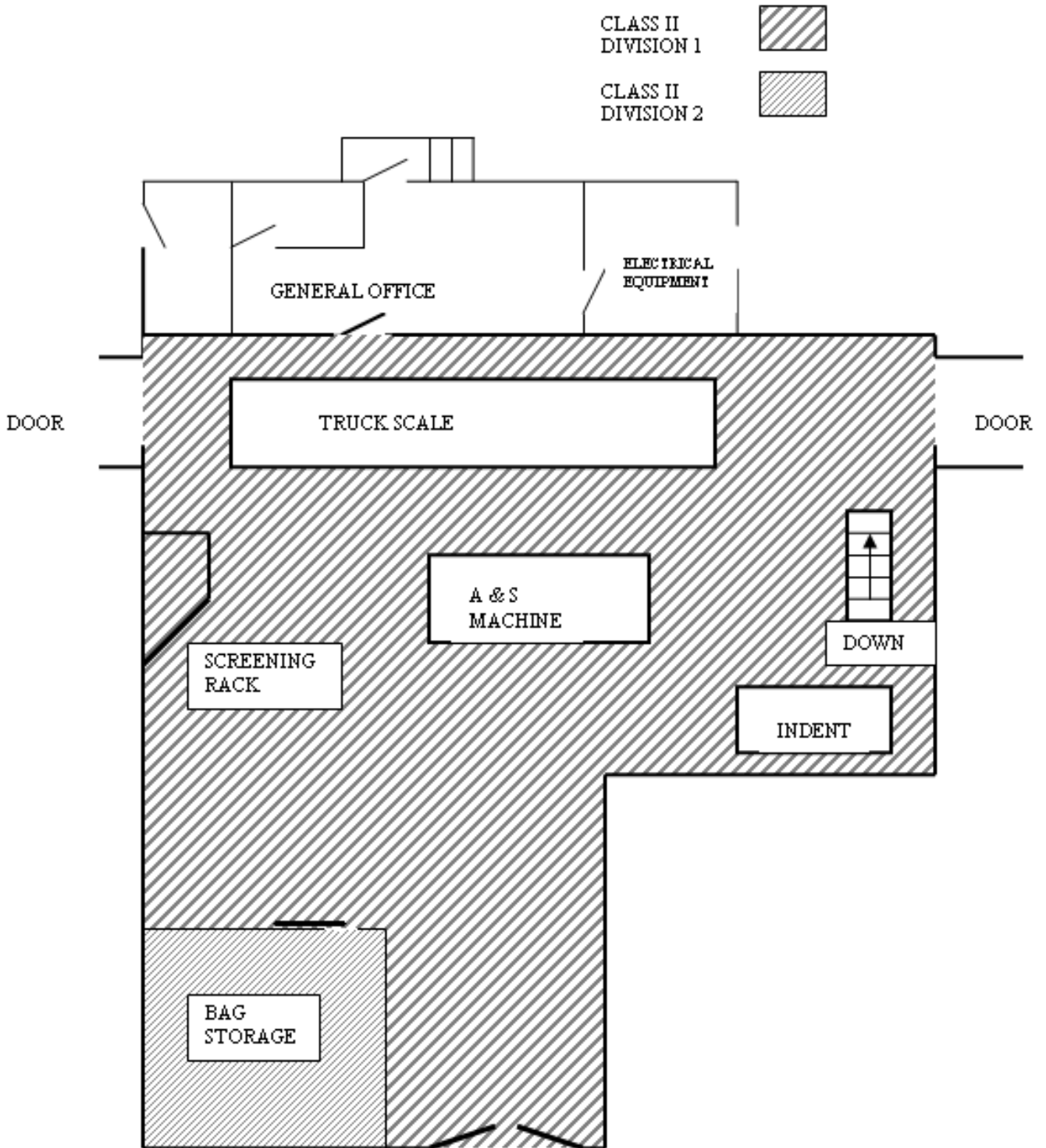



DIAGRAM 13

FEED MILL FLOOR PLAN 18-008 HAZARDOUS AREA CLASSIFICATION

CLASS II
DIVISION 1 

CLASS II
DIVISION 2 

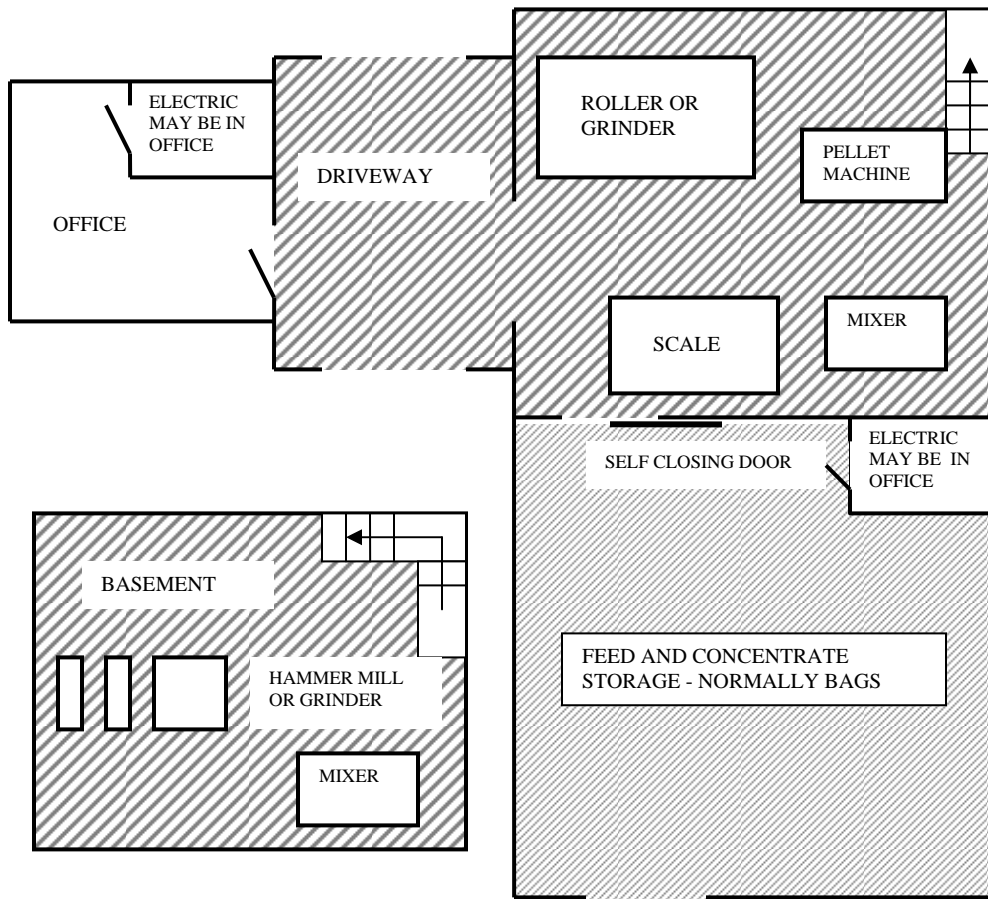
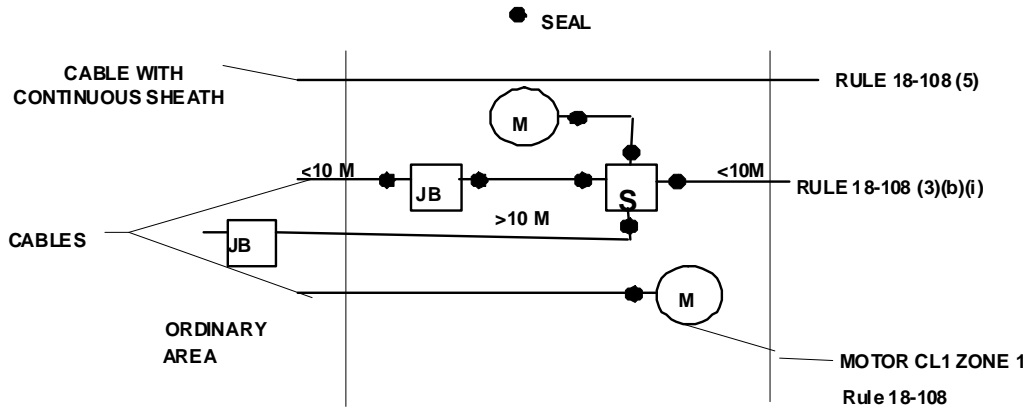
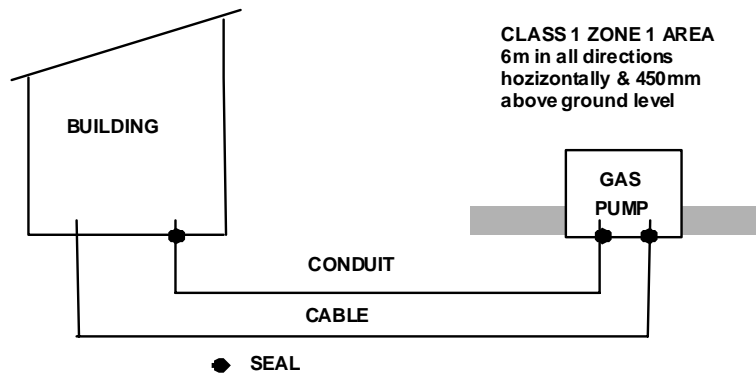
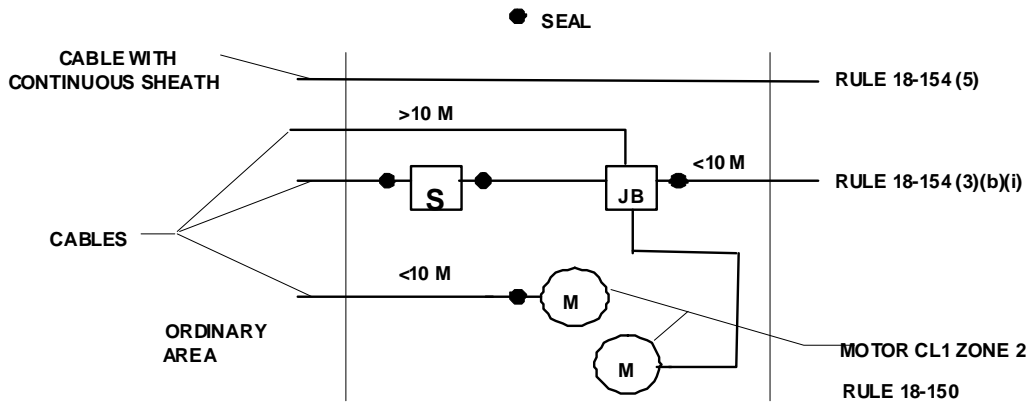

Diagram 14 HAZARDOUS LOCATION SEALING

CLASS 1 ZONE 1 CABLE



CLASS 1 ZONE 2 CABLE



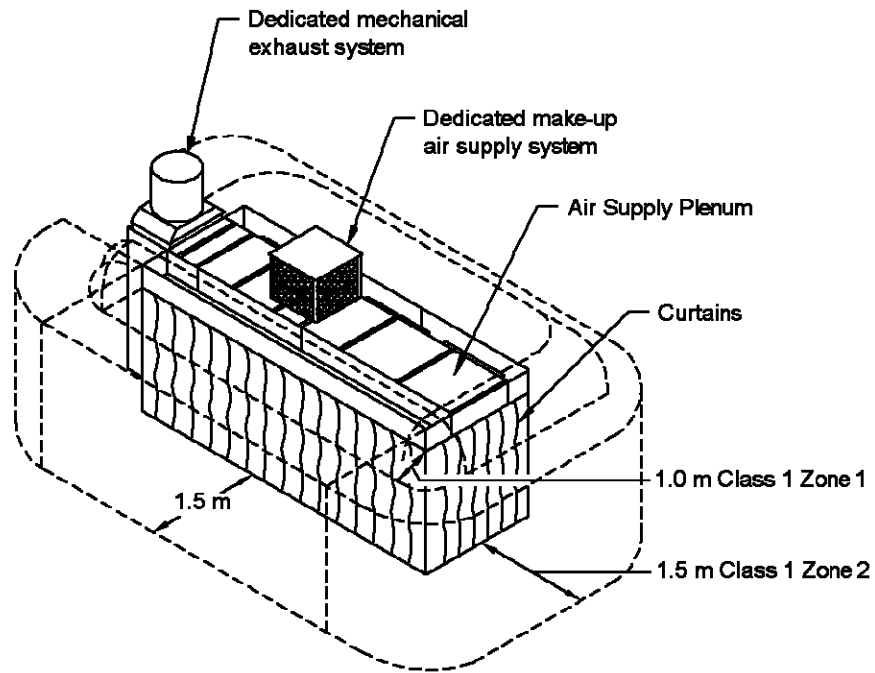

DIAGRAM 16
Class 1 Zone 1; Class 1 Zone 2
Locations Adjacent to a Limited Finishing Workstation
With Exhaust Ventilation Interlocked with Spray Operation

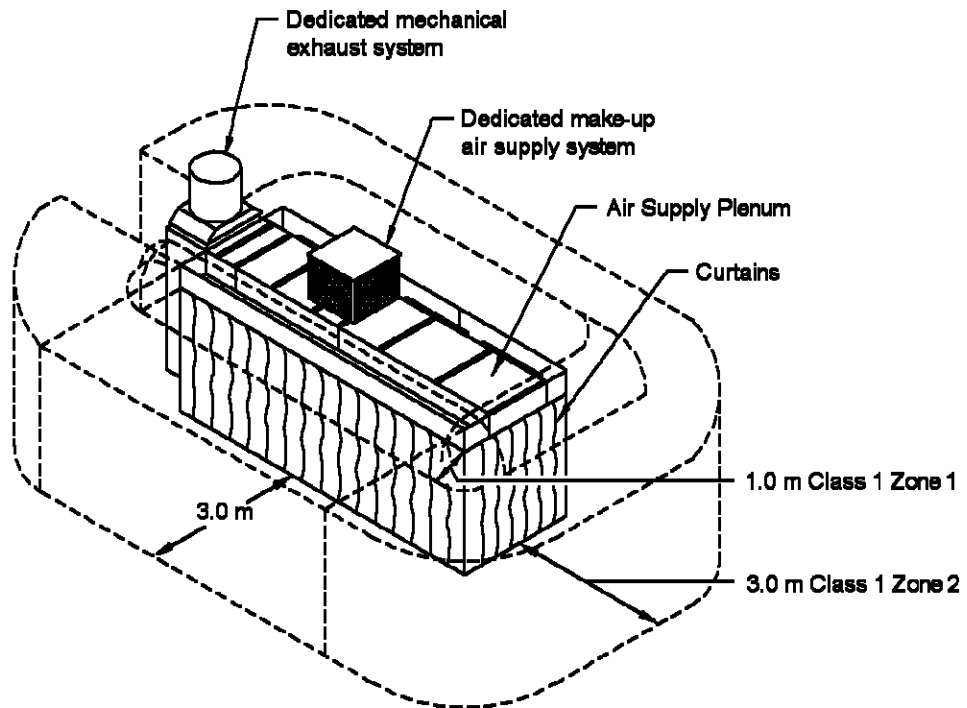

DIAGRAM 17
Class 1 Zone 1; Class 1 Zone 2
Locations Adjacent to a Limited Finishing Workstation
Without Exhaust Ventilation Interlocked with Spray Operation

DIAGRAM 18
Typical Sewage Lift Station (self-contained)

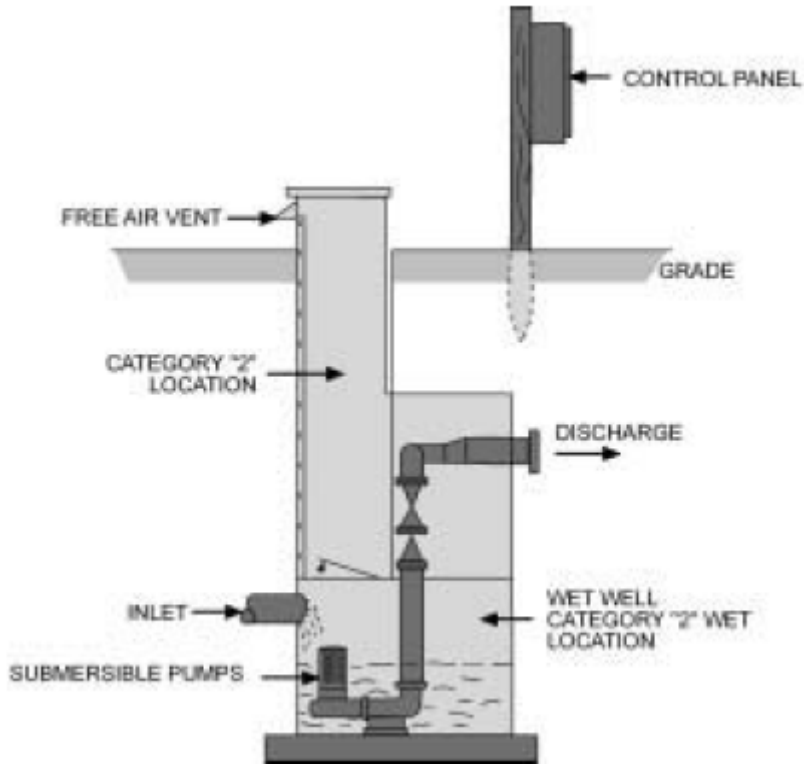

DIAGRAM 19
Typical Sewage Lift Station (control building on top of wet well)

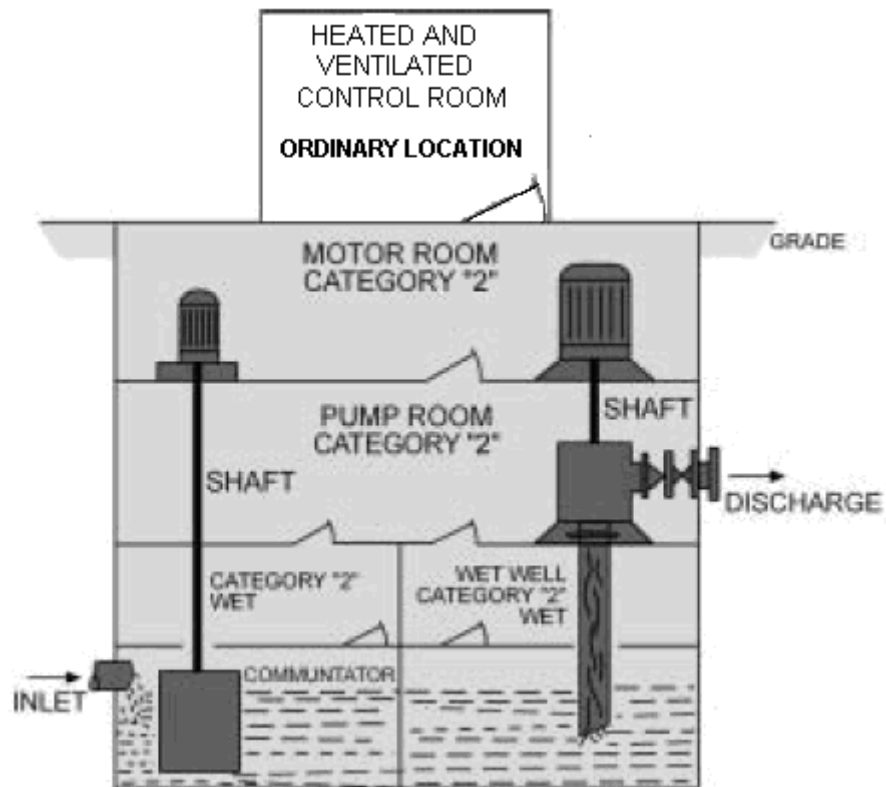

DIAGRAM 20 - Typical Sewage Lift Station (side-by-side)

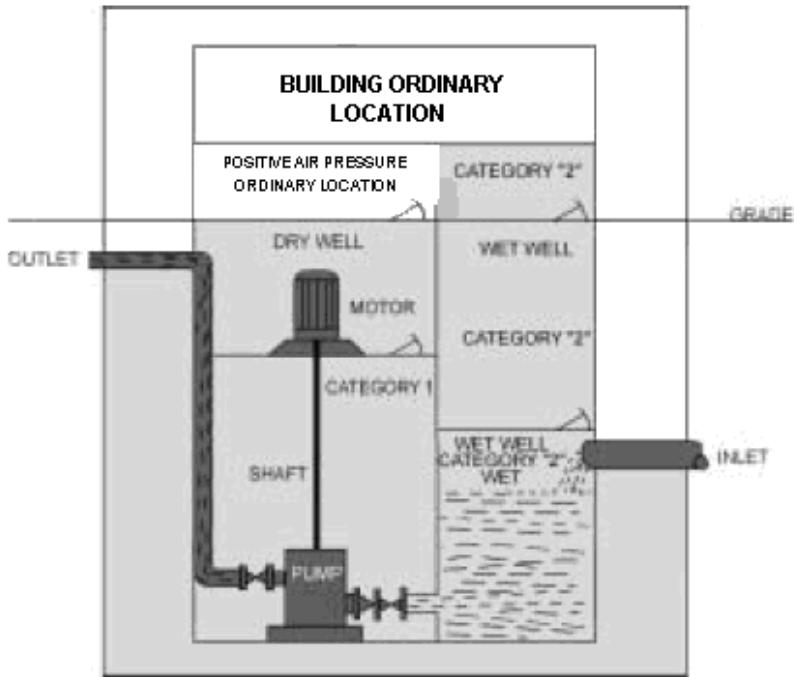
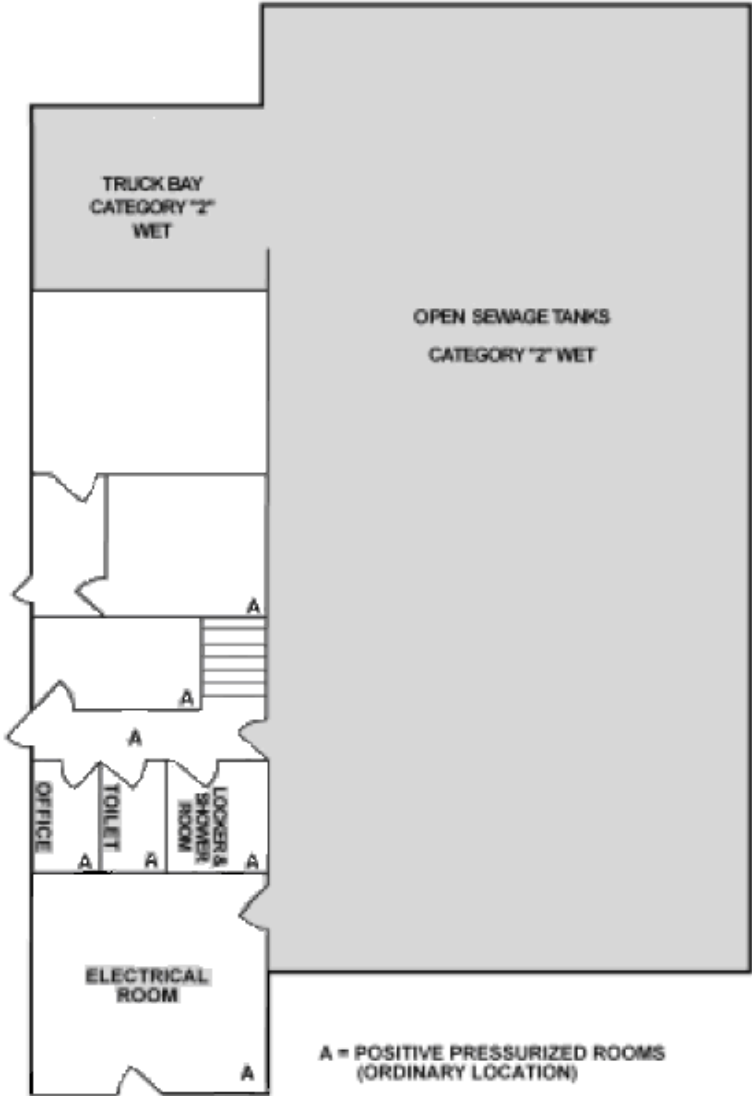

DIAGRAM 21 - Typical Sewage Treatment Plant



The following chart shows the classification of various locations in sewage lift and treatment plants		
Location	Condition	Classification
Wet Wells	With adequate continuous positive pressure ventilation	Class 1, Zone 2
All below-ground location	Suitably cut off from sewage gas location	Category 1 location
All locations	Sewage gas is present in explosive concentrations	Hazardous area and Category 2 location
All locations	Suitably cut off from a Category 2 location and not classified as a Category 1 location	Ordinary location
All locations	Not suitably cut off from a Category 2 location but with adequate continuous positive pressure ventilation	Ordinary location
Below-ground dry well locations	With adequate heating and adequate continuous positive pressure ventilation	Ordinary location

Reference 2009 CEC Handbook

DIAGRAM 22

26-700 (11) – 5-15R or 5-20R within 1.5 m of any sink requires ground fault protection of the Class A type
26-712 (d)(iv) & (v) – at least one 5-15R or 5-20R on each island and peninsula measuring 600mm X 300mm or greater.

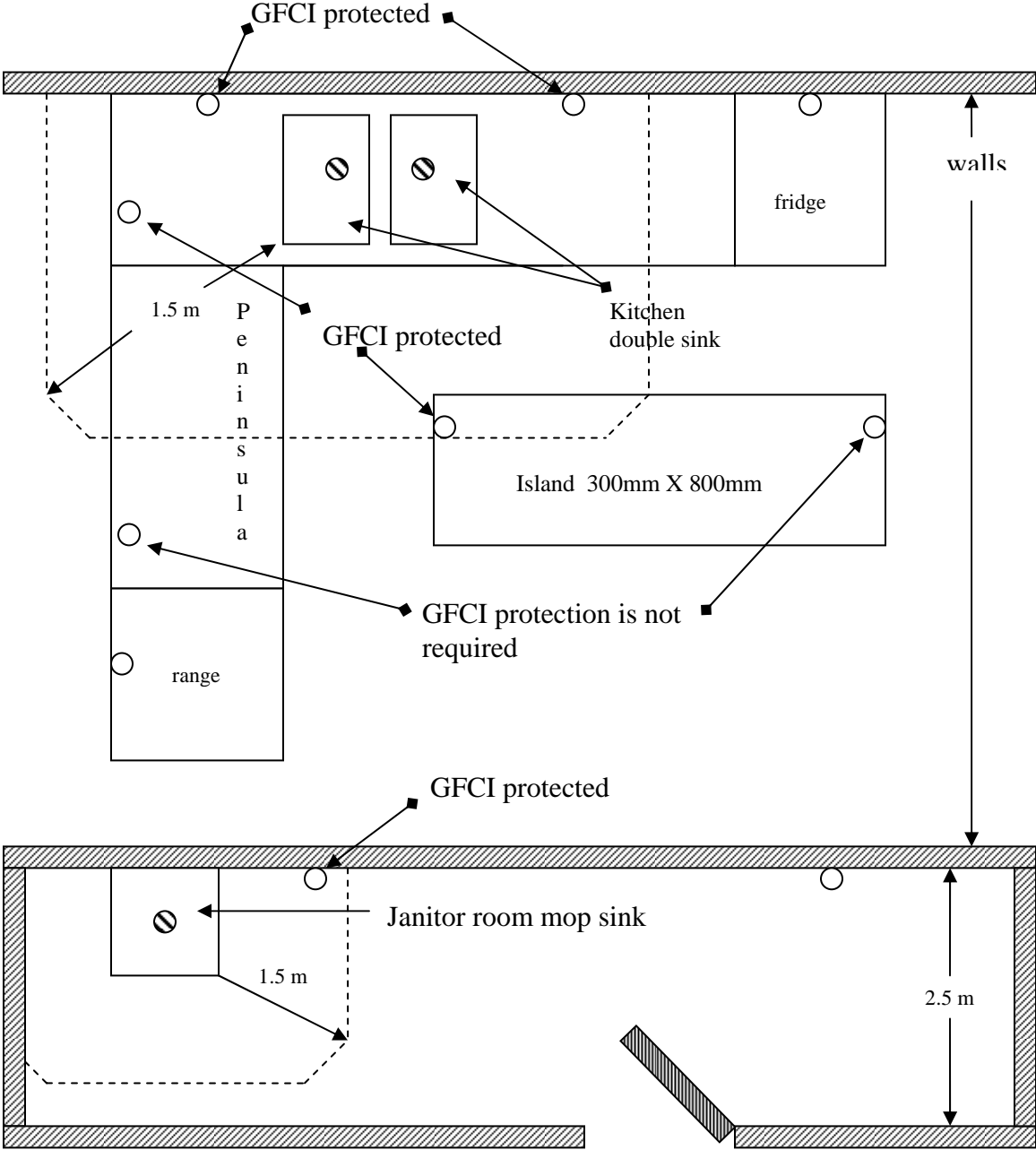

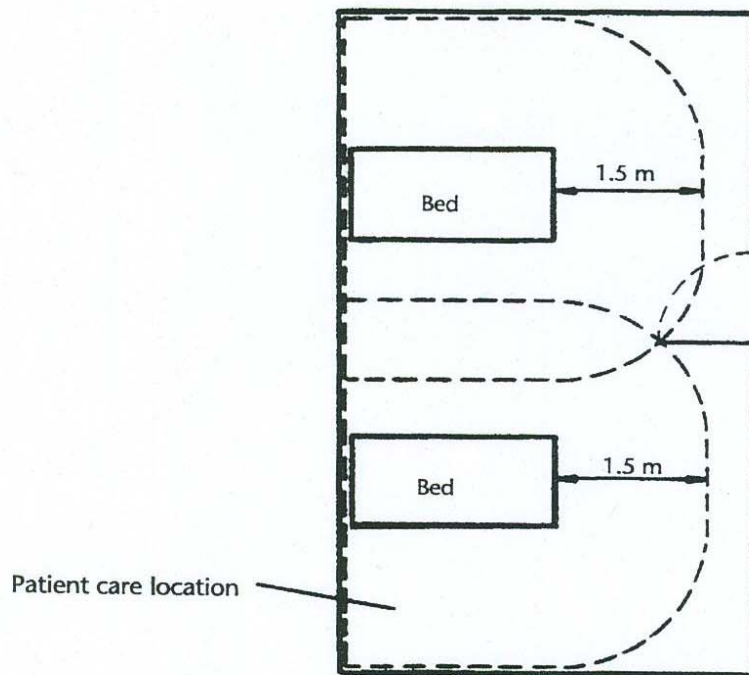
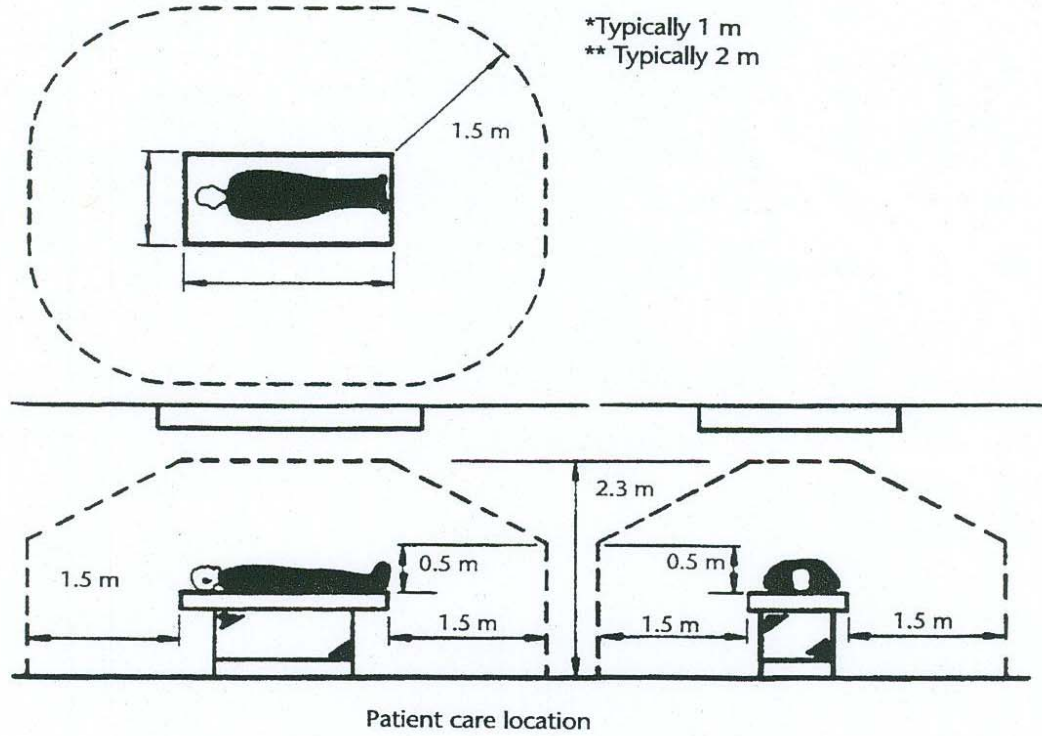

Figure 1
Patient Care Location

Diagram 24

SaskPower Electrical Inspections Department – Phone Numbers and Contacts

Chief Electrical Inspector, Regina 566-2515

Supervisor Electrical Inspector, Regina 566-2516, Cellular 536-4122

Supervisor Electrical Inspector, Saskatoon 934-7720, Cellular 291-8126

Supervisor Business & Technical Services, Regina 566-2518, Cellular 537-2518

Codes and Standards Engineer, Regina 566-2596, Cellular 531-6445

Compliance Officer, Regina 566-2531, Cellular 533-0922

Training Co-ordinator, Regina 566-2600, Cellular 540-4350

District #	Phone Number	Office Location	Address
1A	Office Phone 778-7512	Swift Current	Box 580, 1800 Aberdeen St. Swift Current S9H 3W4
	Fax 778-9158 Cell 741-2807		
1B	Office Phone 778-7519	Swift Current	Box 580, 1800 Aberdeen St. Swift Current S9H 3W4
	Fax 778-9158 Cell 741-0343		
2A	Office Phone 694-8284	Moose Jaw	Box 1240, 880 Lillooet St. West Moose Jaw S6H 4P9
	Fax 692-6838 Cell 630-5311		
2B	Office Phone 694-8257	Moose Jaw	Box 1240, 880 Lillooet St. West Moose Jaw S6H 4P9
	Fax 692-6838 Cell 631-1731		
3	Office Phone 637-4224	Estevan	234 5th St. Estevan S4A 0X8
	Fax 634-9200 Cell 461-9961		
4	Office Phone 637-4235	Estevan	234 5th St. Estevan S4A 0X8
	Fax 634-9200 Cell 421-3703		
5A	Office Phone: 463-5212	Kindersley	Box 1119, Highway # 7 East Kindersley S0L 1S0
	Fax 463-5220 Cell 463-7196		
5B	Office Phone 463-5231	Kindersley	Box 1119, Highway # 7 East Kindersley S0L 1S0
	Fax 463-5220 Cell 460-9608		
6	Office Phone 934-7725	Saskatoon	Box 1560, 1370 Fletcher Rd. Saskatoon S7K 3R3
	Fax 934-7736 Cell 222-4819		
8	Office Phone 786-1270	Yorkton	300 Broadway St. West Yorkton S3N 0M1
	Fax 783-9094 Cell 621-1102		
9A	Office Phone 445-1862	North Battleford	Box 760, 509 Pioneer Ave North Battleford S9A 2Z2
	Fax 445-1870 Cell 441-0511		
9B	Office Phone 445-1861	North Battleford	Box 760, 509 Pioneer Ave North Battleford S9A 2Z2
	Fax 445-1870 Cell 441-3219		
10	Office Phone: 934-7739	Saskatoon	Box 1560, 1370 Fletcher Rd. Saskatoon S7K 3R3
	Fax 934-7736 Cell 221-0918		

District #	Phone Number	Office Location	Address
11	Office Phone 934-7721	Saskatoon	Box 1560, 1370 Fletcher Rd. Saskatoon S7K 3R3
	Fax 934-7736 Cell 221-2960		
12	Office Phone 878-1515	Tisdale	Box 1900, 613 Heritage Rd. Tisdale S0E 1T0
	Fax 878-1548 Cell 873-7399		
13	Office Phone 953-7678	Prince Albert	Box 5900, 1330 Central Ave. E. Prince Albert S6V 7V6
	Fax 953-7609 Cell 961-2634		
14	Office Phone 953-7666	Prince Albert	Box 5900, 1330 Central Ave. E. Prince Albert S6V 7V6
	Fax 953-7609 Cell 961-7470		
15A	Office Phone 566-2530	Regina	1621 Albert Street Regina S4P 0S1
	Fax 566-2906 Cell 536-6550		
15B	Office Phone 566-2528	Regina	1621 Albert Street Regina S4P 0S1
	Fax 566-2906 Cell 529-6992		
15C	Office Phone 566-2532	Regina	1621 Albert Street Regina S4P 0S1
	Fax 566-2906 Cell 536-4665		
15D	Office Phone 566-2529	Regina	1621 Albert Street Regina S4P 0S1
	Fax 566-2906 Cell 536-4121		
15E	Office Phone 566-2541	Regina	1621 Albert Street Regina S4P 0S1
	Fax 566-2906 Cell 536-6549		
16A	Office Phone 934-7725	Saskatoon	Box 1560, 1370 Fletcher Rd Saskatoon S7K 3R3
	Fax 934 -7736 Cell 222-4819		
16B	Office Phone 934-7722	Saskatoon	Box 1560, 1370 Fletcher Rd Saskatoon S7K 3R3
	Fax 934-7736 Cell 222-7794		
16C	Office Phone 934-7724	Saskatoon	Box 1560, 1370 Fletcher Rd Saskatoon S7K 3R3
	Fax 934-7736 Cell 221-0916		
17	Office Phone 786-1243	Yorkton	300 Broadway St. West Yorkton S3N 0M1
	Fax 783-9094 Cell 621-1592		

Regina Office Address
1621 Albert Street
Regina, SK S4P 0S1
Toll Free: 1-888-757-6937, option 5
Fax: 566-2906

Saskatoon Office Address
Box 1560, 1370 Fletcher Rd.
Saskatoon, SK S7K 3R3
Toll Free: 1-888-757-6937, option 5
Fax: 934-7736

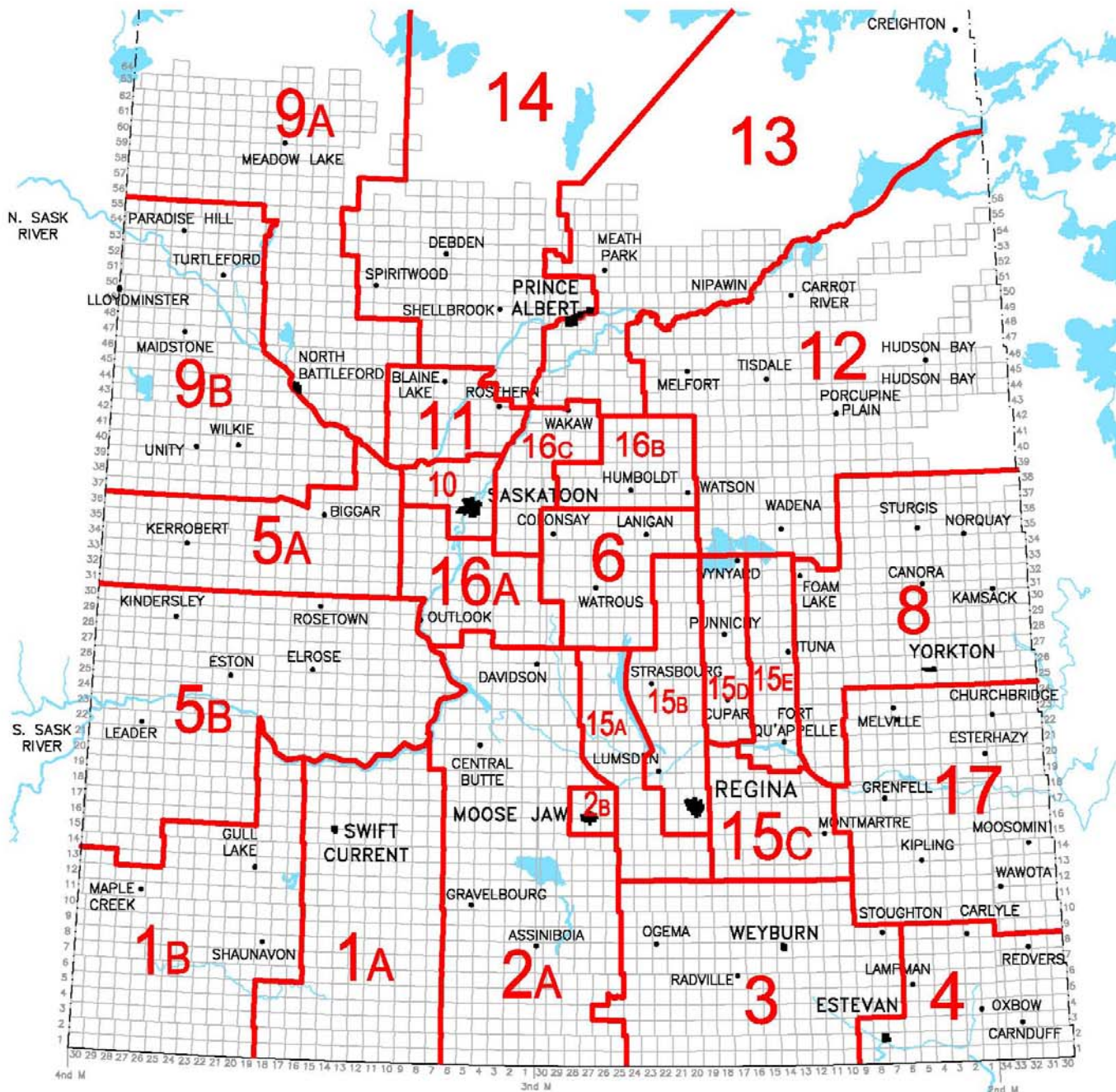

ELECTRICAL INSPECTION DISTRICTS

DISTRICT OFFICE LOCATIONS

- | | | |
|-------------------------|-----------------------|-------------------------|
| 1 – A & B SWIFT CURRENT | 8 – YORKTON | 12 – TISDALE |
| 2 – A & B MOOSE JAW | 9A – NORTH BATTLEFORD | 13 – PRINCE ALBERT |
| 3 – ESTEVAN | 9B – NORTH BATTLEFORD | 14 – PRINCE ALBERT |
| 4 – ESTEVAN | 10 – SASKATOON | 15 – A,B,C,D & E REGINA |
| 5 – A & B KINDERSLEY | 11 – SASKATOON | 16 – A,B,C SASKATOON |
| 6 – SASKATOON | | 17 – YORKTON |